



BAKERLUX SHOP.Pro™ Touch

USAGE MANUAL

# BAKERLUX SHOP.Pro™ Touch

Dear Customer,

Thank you for purchasing a **BAKERLUX SHOP.Pro™** oven.

These ovens are the result of UNOX's continuous research and development; they take up a minimum amount of space but offer excellent performance and outstanding cooking management functions, in any usage conditions.

The **BAKERLUX SHOP.Pro™** ovens use UNOX's finest patented technology, which is the result of its collaboration with leading chefs and research institutions.

A wide array of available accessories make these ovens extremely versatile, and they make your life in the kitchen that little bit easier.

# BAKERLUX SHOP.Pro™ Touch

## INDEX

<b>SAFETY REGULATIONS .....</b>	<b>4</b>
<b>GENERAL USAGE INSTRUCTIONS.....</b>	<b>5</b>
<b>USE .....</b>	<b>6</b>
<b>ALARMS.....</b>	<b>32</b>
<b>ORDINARY AND AFTER-SALES MAINTENANCE .....</b>	<b>33</b>

- Following any procedures other than those indicated in this manual when using or cleaning the appliances is considered inappropriate and may cause damage, injury or death, as well as invalidating the warranty\* and relieving UNOX of all liability.
- Children must not play with the appliance. User cleaning and maintenance must not be carried out by children without supervision.
- Children must be supervised to ensure they do not play with the appliance.
- This appliance can only be used for cooking food in industrial and professional kitchens by qualified personnel, who have completed regular training courses. Any other use is not compliant with the scope of use and is therefore hazardous.
- If the appliance does not function or if you notice any functional or structural alterations, disconnect the electricity and water supply and contact an UNOX-authorized customer assistance service. Do not attempt to repair the appliance yourself. For any repairs, please request UNOX original spare parts.
- Failure to observe these regulations may cause damage, injury or death, and also invalidates the warranty\*.
- To ensure that the appliance is in perfect condition in terms of use and safety, maintenance and inspections should be performed at least yearly by an authorized support service centre.



### RISK OF BURNS AND INJURY

- While cooking and until all appliance parts have cooled, make sure to only touch the appliance control components or handle, because the external parts are extremely hot (temperature above 60°C/140°F).
- Open the door (where necessary) very slowly and carefully, and beware of extremely hot steam coming from the oven cavity.
- Wear appropriate protective thermal clothing to move containers, accessories and other objects inside the oven cavity.
- Be extremely careful when removing trays from the oven cavity.
- Do not remove or touch the protective fan covering, the fans or the heating elements while the appliance is turned on and until they have completely cooled.
- Do not tamper with the oven water circuit in any circumstances because this could cause damage, injury or death. The oven water circuit begins with a 3/4" connector, with a non-return valve built in, and includes all the subsequent piping and accessories.



### RISK OF FIRE

- Before using the appliance, make sure that there are no non-compliant objects (instruction manuals, plastic bags, etc.) or detergent residues inside the oven cavity. Also make sure that the flue is free of obstructions and that there are no flammable materials in the vicinity.
- Do not place sources of heat (e.g. grills, fryers, etc.), highly flammable substances or fuels (e.g. gasoline, petrol, bottles of alcohol, etc.) near the appliance.
- Do not use highly flammable food or liquids while cooking (e.g. alcohol).
- Always keep the oven cavity clean by cleaning every day after each use. Grease or food residues could catch fire if not removed.



### RISK OF ELECTRIC SHOCK

- Do not open the compartments marked with these symbols: access is for qualified personnel authorized by UNOX only. Failure to observe this regulation invalidates the warranty\* and may cause damage or (fatal) injury.

We recommend that the end user have a standard ice-machine filter when using a humidity hookup.

\*For further details, go to the "Warranty" section on the website [www.unox.com](http://www.unox.com)

# BAKERLUX SHOP.Pro™ Touch

## General usage instructions

**!** Before using the appliance, read section "Safety regulations for use" carefully

- When using the appliance for the first time, be sure to clean the inside of the oven cavity and the accessories thoroughly (see page 5); let the oven run empty at maximum temperature for 1 hour to eliminate any unpleasant odours caused by protective factory grease.
- If the appliance is left running for more than 15 minutes without an operating mode being selected, it automatically switches to stand-by to reduce energy consumption. To exit STAND-BY mode, tap the START/ STOP button.
- Use the appliance at a room temperature of between +5°C and +35°C.
- If there is a machine black-out or shut down, when the appliance restarts, the program that was running previously is resumed. The duration of the cooking cycle may be extended by a maximum of 2 minutes.
- **!** For safety reasons, the last tray should NEVER be placed at a height greater than 160 cm. If necessary to do so, **you must apply the sticker contained in the "Starter Kit" at a height of 160 cm.**

## COOKING/LEAVENING ADVICE

- Use the UNOX grills and trays. Try to distribute food uniformly on the trays and avoid overlapping foods or overloading the trays.
- Do not salt food inside the oven cavity. If this cannot be avoided, clean the oven as soon as possible.
- Do not use highly flammable food or liquids while cooking (e.g. alcohol or wine).
- It is always better to preheat the oven to a temperature at least 30°C higher than is required for cooking, in order to reduce the effects of heat loss when opening the door.
- Open the door as little as possible when cooking.
- Try to place the food evenly on the trays, and avoid overlapping foods or overloading the trays (maximum 10 kg per tray). Distribute the trays evenly over the full height of the oven cavity, respecting the maximum number indicated for each appliance.
- Always respect the loading instructions for your oven.
- Beware of touching the external and internal parts of the oven during cooking and until it has completely cooled (it could reach temperatures above 60°C).
- To prevent boiling, do not fill containers with liquids or foods that liquefy with heat in quantities exceeding those that can easily be kept under control.

When navigating and setting parameters only use your finger (which must be clean and dry); avoid using tools such as forks, spoons, etc.

If you have to write the recipe names; use the stylus supplied only.

In case of black-out, you can unlock the door by pressing the button on the side of the oven (only for ovens with an electric lock).

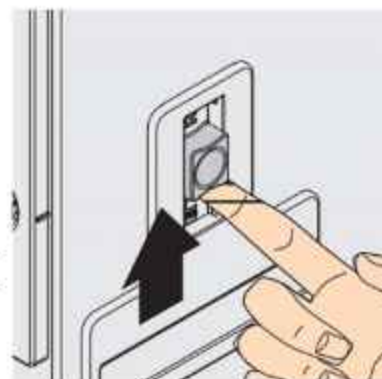

# BAKERLUX SHOP.Pro™ Touch PLUS

Use

Go back to the home screen

Go back to the previous page

Connectivity icons

	Wi-Fi active		3G active
	Wi-Fi not active		3G not active
	Ethernet active		
	Ethernet not active		

Decrease values

Go back to the home screen

For ovens with an electric lock: it opens the oven door

For ovens without an electric lock: if pressed for 2 seconds, the use of the panel unlocks if the door is opened (see further information under "Screen locking" below)

Slider bar

Increase values

**PROGRAMS**  
This allows you to access a list of previously saved recipes with the SET menu. You can reuse a recipe as many times as you want, without having to reset the parameters each time.  
[See further information on page 13 \(cooking\) and 21 \(leavening\)](#)

**SET**  
This enables **manual cooking**, where the user sets the desired parameters  
[More information on page 8](#)

**8**  
This enables **manual leavening**, where the user sets the desired parameters.  
[More information on page 16](#)

**16**  
User parameter settings (date/time, unit of measure, etc.)

The START STOP button starts/stops the cooking or leavening cycle in progress

The button enables you to change programming

TOUCH

## Further information: screen locking



If the oven door is opened, the screen on the side warns that it is not possible to use the display for safety reasons. When the door is closed, the screen is operational again.

### THE SET AND PROGRAMS MENUS

Then you can:

- directly start the recipe: at the end of cooking/leavening, the parameters set will NOT be saved;
- save the recipe set and then start it: at the end of the cooking/leavening cycle, the parameters set are saved and the recipe can be used again in the future, by accessing the **PROGRAMS** menu, without having to reset the parameters.

### WHAT ARE COOKING/LEAVENING STEPS?

Each manual cooking cycle is composed of a **preheating** phase (optional but always recommended) and a series of cooking **steps** (from a minimum of 1 to a maximum of 9), each featuring different cooking parameters. Set multiple steps instead of only one to create the right balance: this translates into better results.



- ❗ To enable use, a cooking/leavening cycle must contain at least one step.
- ❗ Cooking/leavening does not necessarily require all steps: only set the steps which are required. The appliance automatically passes from one step to the next.

### HOW TO SET VALUES

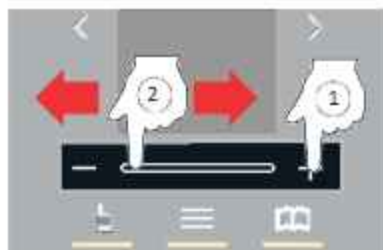

Values are set:

- 1 by pressing the "+" and "-" buttons until you reach the desired value;
- 2 use the "scroll" function by sliding your finger over the bar. Using the scroll function is quicker.

### COUNTDOWN DISPLAYED



HOME screen

During preheating or cooking, the countdown is shown, i.e. the time remaining before the end of the step.

To view the main home screen, press .

From the main home screen, to see the countdown again simply press any of the buttons highlighted in red.



## Oven Set Menu

During **manual cooking**, the user, based on experience, must set the following cooking parameters for one or more cooking steps (up to a maximum of nine):



cooking **duration** (in hours and minutes)



**steam** input



oven cavity **temperature** (°C)





**fan speed**



After setting the cooking parameters (duration, temperature, etc.), you can start cooking directly or save the set recipe: this will allow you to reuse it in the future, without having to reset the parameters every time.

## HOW TO SET A MANUAL COOKING CYCLE

Each manual cooking cycle is made up of a minimum of 1 and a maximum of 9 steps, each with different cooking parameters + an initial preheating phase ("PREHEATING"), which is optional but always recommended.





-  To enable use, a cooking cycle must contain at least one step.
-  A given cooking cycle does not necessarily require all steps: set only those steps which are required.
-  The appliance automatically passes from one cooking step to the next.

### A SELECTING A MANUAL COOKING CYCLE

- 1 Tap:
  - 1A) the icon "MANUAL COOKING CYCLE"  or
  - 1B) the icon "MODIFY"  or the display 
- 2 For point "1B" only: a screen showing two options opens; choose the "MANUAL" (SET) icon.
- 3 parameter setting screen will appear.

### B SETTING COOKING PARAMETERS

This parameter can be modified only when it is highlighted in red; if it is not already highlighted, tap the icon.

-  cooking duration in hours and minutes (setting it to below 0 by pressing the "**(minus)**" button, the time is set to infinity and the oven operates continuously).
-  **temperature** in oven cavity
-  **steam** input
-  **fan speed**





### C SETTING PREHEATING (OPTIONAL)

To set the preheating step:

- 1 tap the symbol <
- 2 Set the desired temperature for preheating.
- 3 Tap the > symbol to return to the parameter setting screen.

An acoustic signal (if active\*) indicates the end of preheating, i.e. the set temperature has been reached.

It is always better to preheat the oven to a temperature at least 30-50°C higher than is required for cooking, in order to compensate for the heat lost when opening the door.

#### Skip the preheating in progress

- 1 Tap the "MODIFY" icon 
- 2 Tap the "SKIP PREHEATING" icon.
- 3 The screen shown appears (INSERT TRAY). When the door is closed, step 1 starts automatically according to the set parameters.

The changes are temporary, i.e. they only apply to the cycle in progress and do not change the original recipe if saved.



### D SETTING THE NEXT STEPS (WHERE NECESSARY)

To set the following steps (if needed):

- 1 tap the symbol > ; all available steps will be displayed; only set the ones you need.
- 2 Repeat the operations explained in section B to set all cooking parameters from step "2" onwards.



## E START/SAVE COOKING

After having set the cooking parameters (duration, time, etc.), you can:





- directly start the recipe: at the end of the cooking cycle, the parameters set will NOT be saved;
- save the recipe set and then start it: at the end of the cooking cycle, the parameters set are saved and the recipe can be used again in the future, without having to set the parameters each time.

### Starting cooking directly

- 1 Press the "START/STOP" icon: cooking will start with the set parameters.



### Save the cooking cycle and then start it

- 1 Tap the "MODIFY" icon 
- 2 Tap the "-----" field.
- 3 You can set the **name** you want to give the recipe using one of the two following methods:
  - A typing the name on a keypad  and confirming with "ok" .
  - B writing the name with the stylus provided  and confirming with "ok" .

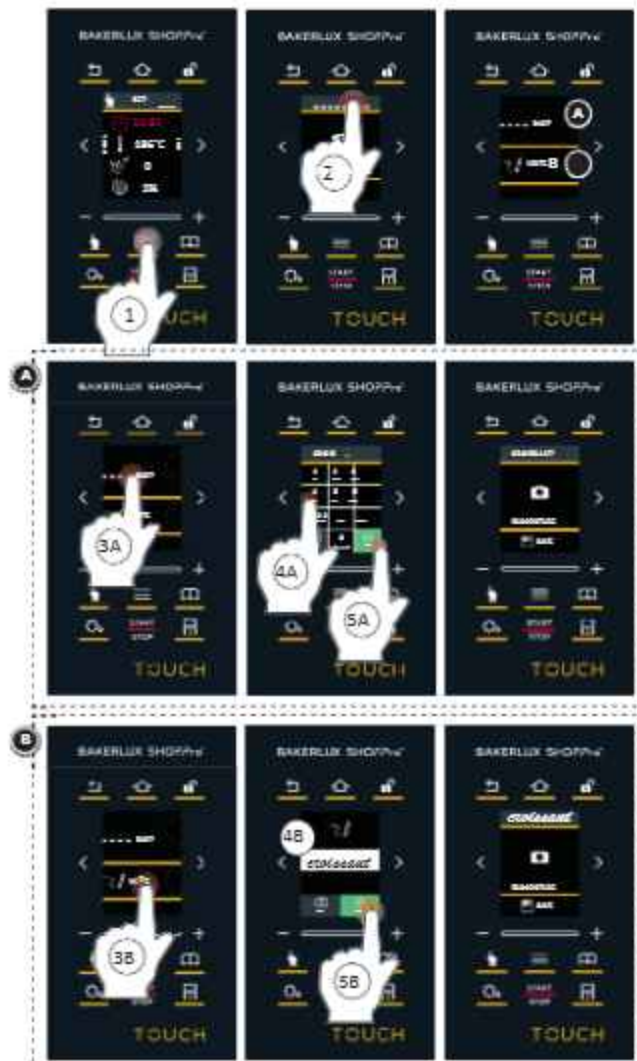

- 6 Tap the "PROG PICTURE" icon
- 7 Choose the photo to go with the recipe.
- 8 Press the "save" key to save the recipe.
- 9 The recently saved program is automatically stored in the last position, after the other programs already in the memory.

The screen shows the "CROISSANT" recipe has been added and saved.

- To use the saved cooking cycles, access the "PROGRAMS" section [section "Oven Programs: Menu" on page 13](#)

You do not need to assign a name and photo to the recipes that you want to save. In this case, instead of the recipe name, the word "PROG" and a number will appear. Again, the program is automatically saved in the last position, after the other programs already in the memory.

- 10 Press the "START/STOP" icon: cooking will start with the set parameters.



## COOKING IN PROGRESS

- 1 If the cooking cycle requires preheating, the oven starts to heat the cavity to bring it to the set temperature (in the example: 180°C). DO NOT place the dishes in the oven during this phase.

To skip preheating see [section "Skip a preheating cycle in progress" on page 17](#)

- 2 At the end of preheating, the oven beeps and the screen shown (INSERT TRAY) appears. You should now put the food in the oven. When the door is closed, step 1 automatically starts according to the set parameters.
- 3 During the cooking cycle, the time remaining until the cycle is complete is shown on the screen (in the example: 12 minutes and 6 seconds), as well as the temperature (in the example: 180°C).

To view or change the parameters of a cooking cycle in progress (e.g. lower the temperature or extend the time), see [section View/modify the parameters of a cooking cycle or preheating in progress on page 12](#)

If you want to stop the cooking cycle in progress, hold down the "START/STOP" button (approximately 4-5 seconds).





## View/modify the parameters of a cooking cycle or preheating in progress

### SOLUTION A

- ① Tap the "MODIFY" icon 
- ② Tap the "VIEW MODIFY" icon.
- ③ Modify parameters as usual (see "Setting cooking parameters" on page 8)
- ④ Tap the "MODIFY"  icon to save the changes made.
- ⑤ To exit the screen, tap the "GO BACK" icon or wait  10 seconds

### SOLUTION B





- ① Tap the symbols  or 
- See points ③ ④ and  for solution "A".
- ⑤

The changes are temporary, i.e. they only apply to the cooking/preheating cycle in progress. They do not change the original recipe if it is saved.

 To stop a preheating phase in progress, see page 17

### COOKING END

Cooking ends when the set time has elapsed; if you want to stop cooking before the end of the set time, hold down the "START/STOP" button. At the end of the cooking cycle, the oven beeps to indicate that the dishes are ready. At the end of the cooking cycle, you can:

- ① **add time** (for example, I have checked that the food is still not cooked).  
1A-1B-1C-1D: Tap the  icon, set the additional minutes and restart the cooking cycle with "START/STOP".
- ② **repeat** the cooking cycle that has just been completed keeping the same parameters.  
2A-2B: Tap the icons "MODIFY"  and "REPEAT" .
- ③ **save** the cooking cycle that has just been completed if it has not already been saved.  
3A-3B: Tap the "MODIFY"  and "SAVE"  icons. Then, save the cooking cycle as usual (see "save the cooking cycle" on page 10).

To return to the home screen, press the "HOME"  button.

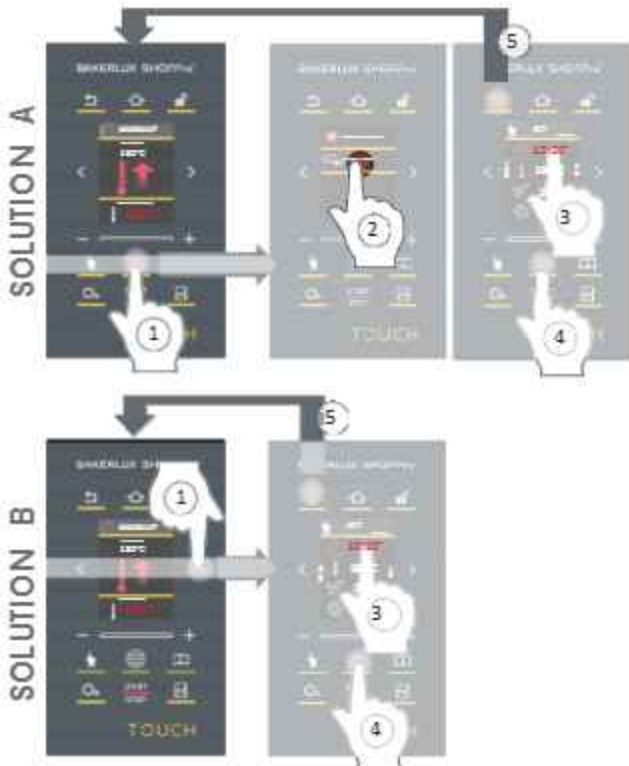





## Oven Programs Menu

Using this menu, you can view and use the recipes stored previously by the user, after setting them manually (SET menu). The oven can store up to 99 recipes (from P1 to P99).

### CALLING UP A SAVED RECIPE

- 1 Tap:
  - 1A) the icon "PROGRAMS"  or
  - 1B) the icon "MODIFY"  or the display.
- 2 For point "1B" only: a screen showing two options appears; choose the "PROGRAMS" icon.
- 3 The list of cooking cycles saved previously will appear using the "SET MENU" (in the example the "croissant" recipe was selected).  
To scroll through all of the programs, use the < or > symbols.
- 4 Press the "START/STOP" icon: cooking will start with the set parameters.
- 5 If the cooking cycle requires preheating, the oven starts to heat the cavity to bring it to the set temperature. DO NOT place dishes in the oven during this phase.

To skip preheating, see section "Skip a pre-heating cycle in progress" on page 17

- 6 At the end of preheating, the oven beeps and the screen shown (INSERT TRAY) appears. You should now put the food in the oven. When the door is closed, step 1 automatically starts according to the set parameters.
- 7 During the cooking cycle, the time remaining until the cycle is complete is shown on the screen (in the example: 12:06), as well as the temperature (in the example: 180°C). Cooking ends when the set time has elapsed; if you want to stop cooking before the end of the set time, hold down the "START/STOP" button. At the end of the cooking cycle, the oven beeps to indicate that the dishes are ready.

To view or change the parameters of a cooking cycle in progress (e.g. lower the temperature or extend the time), see section "View/modify the parameters of a cooking cycle or preheating in progress" on page 12).



## MODIFY THE PARAMETERS OF A SAVED COOKING CYCLE DUPLICATE A SAVED COOKING CYCLE DELETE A SAVED COOKING CYCLE

- 1 Tap the "PROGRAMS" icon 
- 2 The list of cooking cycles saved previously will appear using the "SET MENU" (in the example the "croissant" recipe was selected).

- 3 Tap the "MODIFY" icon 
- 4 The modification screen appears. You can:

**A (VIEW/MODIFY) view the parameters for the selected recipe and change where necessary, follow the usual procedure (see "Setting cooking parameters" on page 8). The changes will be PERMANENT, or rather, the original recipe will be changed (the example shows the "croissant" recipe).**

**B Duplicate the original recipe to create a new one: the original recipe is NOT changed. To set and save the new duplicated recipe, see "Setting cooking parameters" on page 8 and section "Save the cooking cycle and then start it" on page 10.**

**C Delete the recipe permanently (it is removed from the list of recipes).**

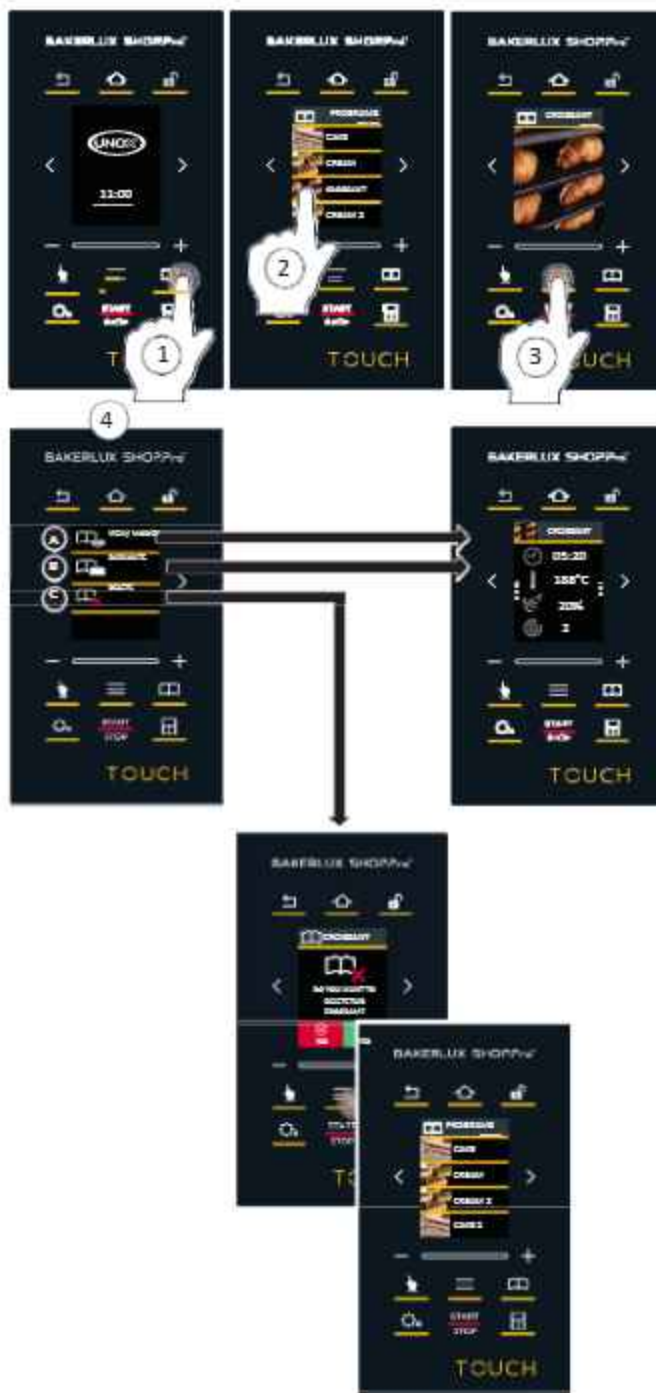

## COOKING END

Cooking ends when the set time has elapsed; if you want to stop cooking before the end of the set time, hold down the "START/STOP" button. At the end of the cooking cycle, the oven beeps to indicate that the dishes are ready.

At the end of the cooking cycle, you can:

- 1 add time** (for example, I have checked that the food is still not cooked).  
1A-1B-1C-1D: Tap the  set the additional minutes and restart  cooking cycle with "START/STOP".  
  
  
  

- 2 repeat** the recipe that has just been completed, keeping the same parameters.  
2A-2B: tap the "MODIFY" and "" icons  
  

- 3 save** the cooking cycle that you have just completed, if changes have been made.  
3A-3B: Tap the icons "MODIFY"  and "SAVE"  
  
  
Then, save the cooking cycle as usual (see "[save the cooking cycle](#)" on page10).

To return to the home screen, press the "HOME"

 button.

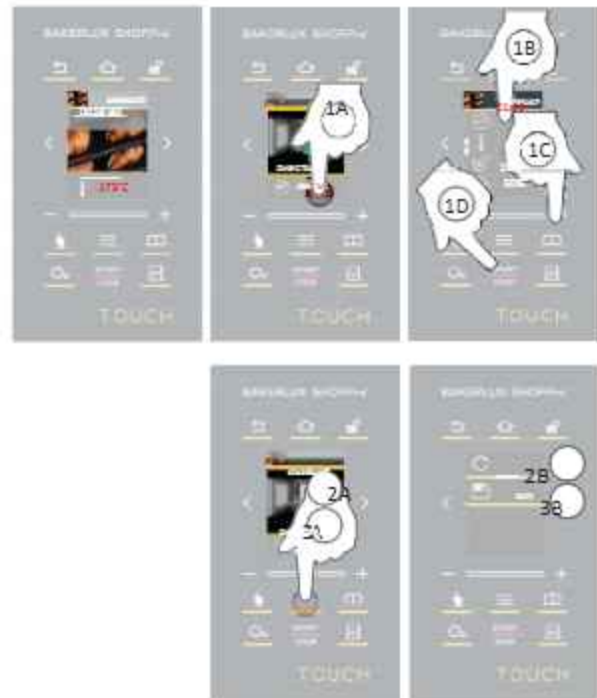



## Prover Set Menu

Your BAKERLUX SHOP.Pro™ appliance can control a prover from the same series, which is connected to it. The user must set the following parameters during **manual leavening**, depending on experience:



leavening **duration** (in hours and minutes);



**temperature** in the oven cavity (°C)

After setting the parameters, you can start leavening directly or save the set recipe: this will allow you to reuse it in the future, without having to reset the parameters every time.



## HOW TO SET A MANUAL LEAVENING PROCESS

### A SELECT THE APPLIANCE

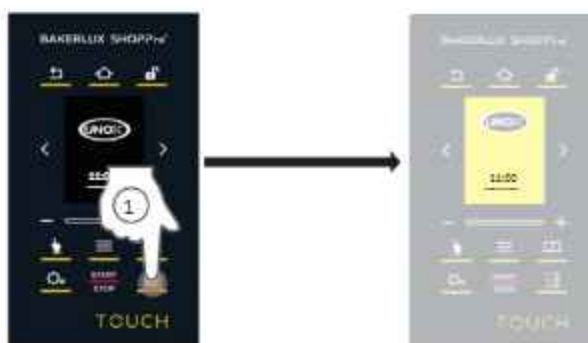
- 1 Select the "PROVER" button: the control panel is now enabled to use this appliance.



### B SELECTING MANUAL LEAVENING

- 1 Tap:
  - A) the icon "MANUAL LEAVENING"  or
  - B) the icon "MODIFY"  or the display
- 2 For point "B" only: a screen showing two (SET) icon.
- 3 The parameter setting screen will appear.

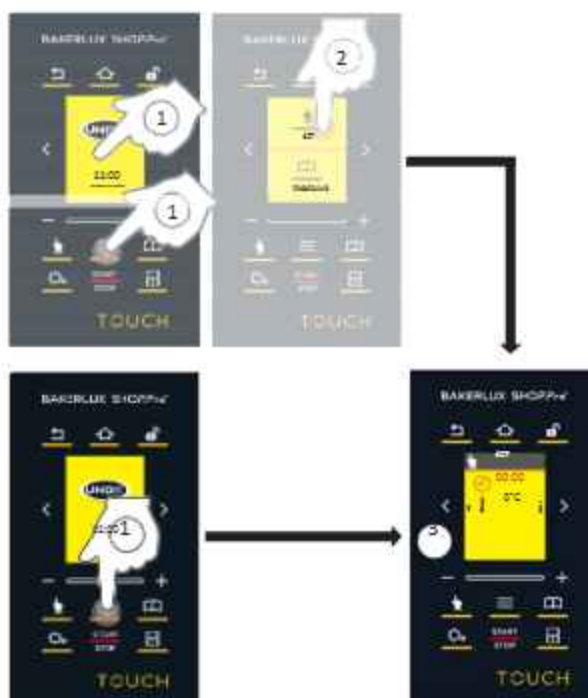



### C SETTING LEAVENING PARAMETERS

This parameter can be modified only when it is highlighted in red; if it is not already highlighted, tap the icon.



 leavening **duration** in hours and minutes (setting it to below 0 by pressing the "**(minus)**" button, the time is set to infinity and the prover operates continuously).

 **temperature** in oven cavity



### D SETTING THE PREHEAT (OPTIONAL)

To set the preheating step: tap

- ① the symbol 
- ② Set the desired temperature for preheating.
- ③ Tap the  symbol to return to the parameter setting screen.

An acoustic signal (if active\*) indicates the end of preheating, i.e. the set temperature has been reached.

 It is always better to preheat the prover in order to compensate for the heat lost when opening the door.

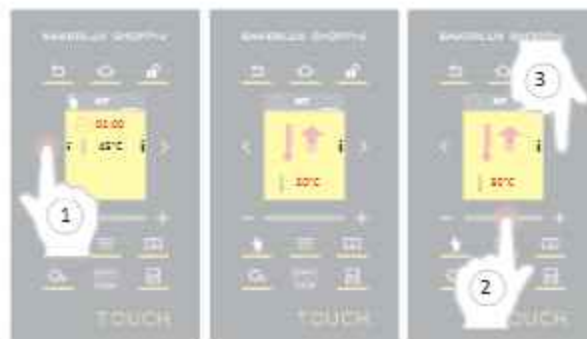

PROVER SET

### Skip a preheating cycle in progress

- ① Tap the "MODIFY" icon 
- ② Tap the "SKIP PREHEATING" icon.
- ③ The screen shown appears (INSERT TRAY). When the door is closed, step 1 starts automatically according to the set parameters.

The changes are temporary, i.e. they only apply to the cycle in progress and do not change the original recipe if saved.



### E SETTING THE NEXT STEPS (WHERE NECESSARY)

To set the following steps (if needed):

- ① tap the symbol ; all steps available will be displayed; only set the ones you need.
- ② Repeat the operations explained in the previous section to set all cooking parameters from step "2" onwards.



## F START/SAVE THE LEAVENING PROCESS

After having set the leavening parameters, you can:

- directly start the recipe: at the end of leavening the parameters set will NOT be saved;
- save the recipe set and then start it: at the end of the leavening cycle, the parameters set are saved and the recipe can be used again in the future, without having to set the parameters each time.

### Start leavening directly

- 1 Press the "START/STOP" icon: leavening will start with the set parameters.



### Save the leavening cycle and then start it

- 1 Tap the "MODIFY" icon 
- 2 Tap the "-----" field.
- 3 You can set the **name** you want to give the recipe using one of the two following methods:
  - A typing the name on a keypad (4A) and confirming with "ok" (5A)
  - B writing the name with the stylus provided (4B) and confirming with "ok" (5B)



- 6 Tap the icon "PROG PICTURE"
- 7 Choose the photo to go with the recipe.
- 8 Press the "SAVE" key to save the recipe.
- 9 The recently saved program is automatically stored in the last position, after the other programs already in the memory.

The screen shows the "CROISSANT" recipe has been added and saved.

To use the saved cooking cycles, access the "PROGRAMS" section **section "Prover Programs Menu" on page 21**

You do not need to assign a name and photo to the recipes that you want to save. In this case, instead of the recipe name, the word "PROG" and a number will appear. Again, the program is automatically saved in the last position, after the other programs already in the memory.

- 10 Press the "START/STOP" icon; cooking will start with the set parameters.



PROVER SET

## LEAVENING IN PROGRESS

- 1 If leavening requires preheating, the prover starts to heat the cavity to bring it to the set temperature (in the example 70°C). DO NOT place dishes in the prover during this step.

To skip preheating, see **section "Skip a preheating cycle in progress" on page 17**

- 2 At the end of preheating, the prover beeps and the screen shown appears (INSERT TRAY). Put the food in the oven. When the door is closed, step 1 starts automatically according to the set parameters.
- 3 During leavening, the time remaining until the cycle is complete is shown on the screen (in the example: 47 minutes), as well as the temperature in the cavity (e.g. 45°C).

To view or change the parameters for a leavening cycle in progress (e.g. lower the temperature or extend the time), see **section View/modify the parameters of leavening or preheating in progress on page 20**

- 20 If you want to stop the cooking cycle in progress, hold down the "START/STOP"

button (approximately 4-5 seconds).





continuous operation



time

## View/modify the parameters of leavening or preheating in progress

### SOLUTION A

- ① Tap the "MODIFY" icon 
- ② Touch the "VIEW MODIFY" icon.
- ③ Modify parameters as usual (see section "Setting leavening parameters" on page 17)
- ④ Tap the "MODIFY"  icon to save the changes made.
- ⑤ To exit the screen, tap the "GO BACK" icon  or wait 10 seconds

### SOLUTION B

- ① Tap the symbols  or 
- See points ③ ④ and ⑤ for solution "A".

The changes are temporary, i.e. they only apply to the cooking/preheating cycle in progress. They do not change the original recipe if it is saved.

To stop preheating in progress, see page 17

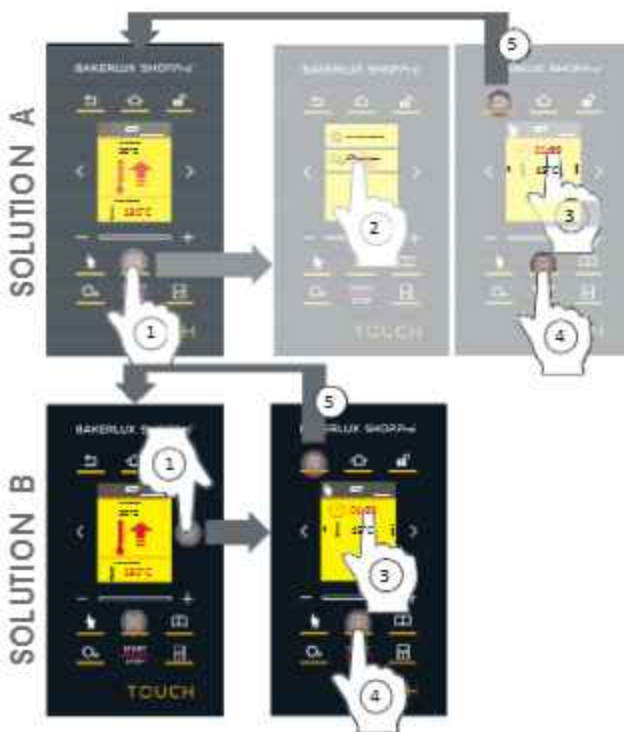

## 6 LEAVENING COMPLETE

Leavening ends when the set time has elapsed; if you want to interrupt cooking before the end of the set time, hold down the "START/STOP" button. At the end of the leavening cycle, the oven beeps to indicate that the dishes are ready.

At the end of leavening, you can:

- ① **stop the beep** and stop leavening;
- ② **repeat** the leavening cycle as soon as it has finished, using the same parameters.  
2A-2B: Tap the icons "MODIFY"  and "REPEAT" .
- ③ **save** the leavening cycle that has just finished, if it has not already been saved.  
3A-3B: Tap the "MODIFY"  and "SAVE"  icons.

Then, save the leavening as usual (see "Save leavening cycle" on page 18).

To return to the home screen, press the "HOME"  button.





## Prover Programs Menu

Using this menu, you can view and use the recipes stored previously by the user, after setting them manually (SET menu). The oven can store up to 99 recipes (from P1 to P99).

### CALLING UP A SAVED RECIPE

1 Select the "PROVER" button: the control panel is now enabled to use this appliance.

2 Tap:

A) the icon "PROGRAMS"



or

B) the icon "MODIFY"



or the display

3 For point "B" only: a screen showing two options opens appears; choose the "PROGRAMS" icon.

4 The list of leavening cycles saved previously appears using the "SET MENU" (in the example the "croissant" recipe was selected).

To scroll through all of the programs, use the < or > symbols.

5 Press the "START/STOP" icon: leavening will start with the set parameters.

6 If the leavening requires preheating, the prover starts to heat the cavity to bring it to the set temperature. DO NOT place dishes in the prover during this step.

To skip preheating, see section "Skip a pre-heating cycle in progress" on page 17

7 At the end of the preheating, the prover beeps and the screen shown appears (INSERT TRAY). Put the food in the oven. When the door is closed, step 1 automatically starts according to the set parameters.

8 Leavening ends when the set time has elapsed; if you want to interrupt cooking before the end of the set time, hold down the "START/STOP" button. At the end of the leavening cycle, the prover beeps to indicate that the dishes are ready.

To view or change the parameters of a cooking cycle in progress (e.g. lower the temperature or extend the time) see section "Setting leavening parameters" on page 17.

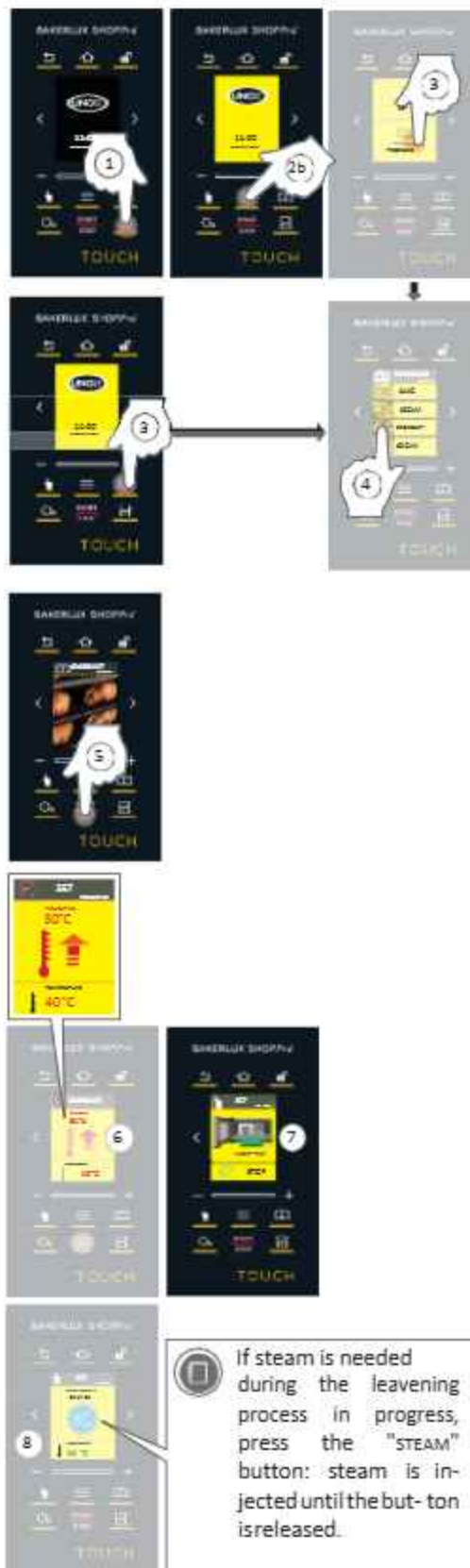

PROVER SET

## MODIFY THE PARAMETERS OF A LEAVENING CYCLE SAVED IN THE MEMORY

### DELETE A SAVED LEAVENING CYCLE

- 1 Select the "PROVER" button: the  panel is now enabled to use this appliance.
- 2 Tap the "PROGRAMS" icon
- 3 The list of cooking cycles saved previously will the "croissant" recipe was selected 
- 4 Tap the "MODIFY" icon
- 5 The modification screen appears. You can:

**(VIEW/MODIFY) view the parameters for necessary,** follow the usual procedure (see "Set-

changes will be PERMANENT, or rather, the original recipe will be changed (the example shows the "croissant" recipe).

**Duplicate the original recipe** to create a new one: the original recipe is NOT changed. To set and save a new duplicated recipe, see "Setting leavening parameters" on page 17 and section "Save the leavening cycle and then start it" on page 18.

**Delete the recipe** permanently (it is removed from the list of recipes).

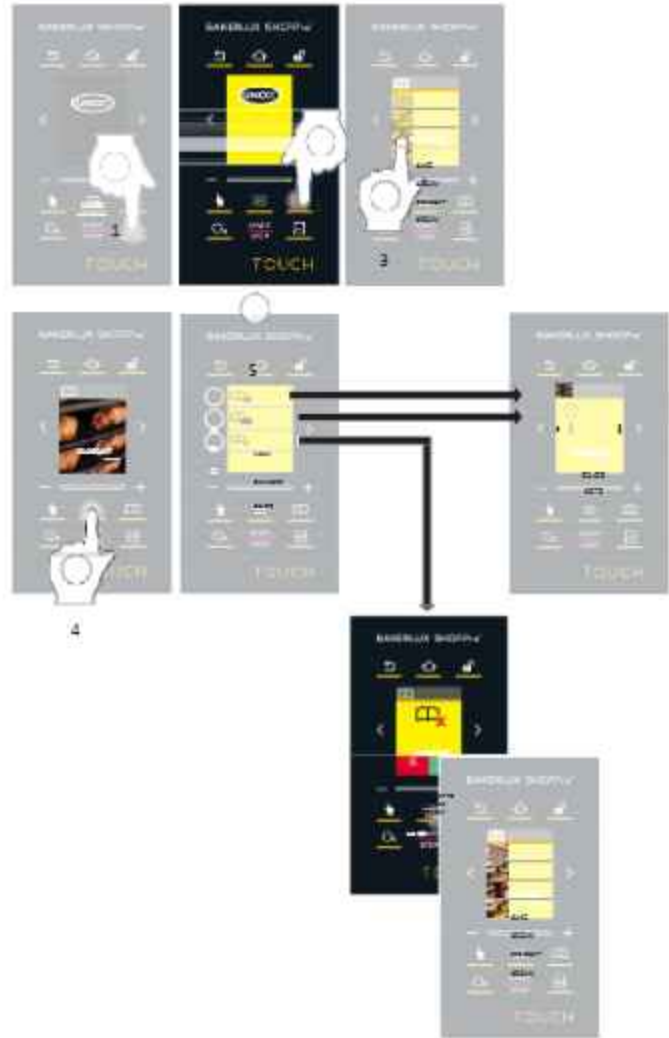

## LEAVENING COMPLETE

Leavening ends when the set time has elapsed; if you want to stop cooking before the end of the set time, hold down the "START/STOP" button. At the end of the leavening cycle, the prover beeps.

At the end of leavening, you can:

- 1 **stop the beep** and stop leavening;
- 2 **repeat** the leavening cycle as soon as it has finished, using the same parameters.

Tap the icons "MODIFY"



and "REPEAT"



- 3 **save** the leavening cycle that has just finished, if it has not already been saved.

Tap the icons "MODIFY"



and "SAVE"



Then, save the leavening as usual (see "[Start/save the leavening process](#)" on page 18).

To return to the home screen, press the "HOME"



button.





## Settings

This menu enables the user to set the oven parameters.

The SERVICE MENU is for specialist operators only, whereas the "USER SETTINGS" can be accessed by any operator by entering the password "4456" and confirming with "OK".

A screen is shown containing a series of submenus which you can scroll through using the < or > symbols.



### LANGUAGE

Here you can select your preferred language, which will be used for all menu entries. You can scroll through the list of languages using the < or > symbols:

ENGLISH, ITALIANO, FRANÇAIS, ESPAÑOL, DEUTSCH, CESKY, РУССКИЙ, KOREAN, SRPSKI, CHINESE, SLOVENSKY, PORTUGUÊS, JAPANESE, ROMANA, DANSK, SVENSKA, POLSKI, SLOVENŠČINA, NEDERLANDS, БЪЛГАРСКИ, ไทย, ΕΛΛΗΝΙΚΑ, MAGYAR, TÜRK, HRVATSKI and EESTI

The chosen language is highlighted in green.



### UNIT OF MEASURE

The user can select the unit of measurement:  
- for the temperature (°C/°F);  
- for the volume (litres/gallons).

The selected entries are highlighted in green.





## 3 DATE AND TIME

The following values must be set:

### A the **time zone**:

- click on the geographical area (it will be highlighted in yellow) and confirm

your choice using 

- select your country by scrolling through the list using the < or > symbols.

### B whether to use the **automatic time** feature (only where the oven is connected to a network):

- "YES": the time is detected via the network and is updated automatically;
- "NO": the time must be set manually. The chosen entry is highlighted in green.

### C if the time should change when switching from **standard time to daylight time saving** and vice versa.

- "YES": the time is updated automatically, increasing or decreasing by one hour on the required day (in October and March).
- "NO": the time remains unchanged and, if necessary, must be changed manually. The chosen entry is highlighted in green.

 If the automatic time option has been set, you do not need to set this entry, because the time will be changed automatically.

 **D-E** the day, month, year and time in hours and minutes. To enter the values, click on the entry you want to set, enter the desired value using the keypad and confirm by pressing "OK". To access the day, month and time parameters, tap

the > symbol.

 If the automatic time option has been set, you do not need to set the hours and minutes, because the network time is used.

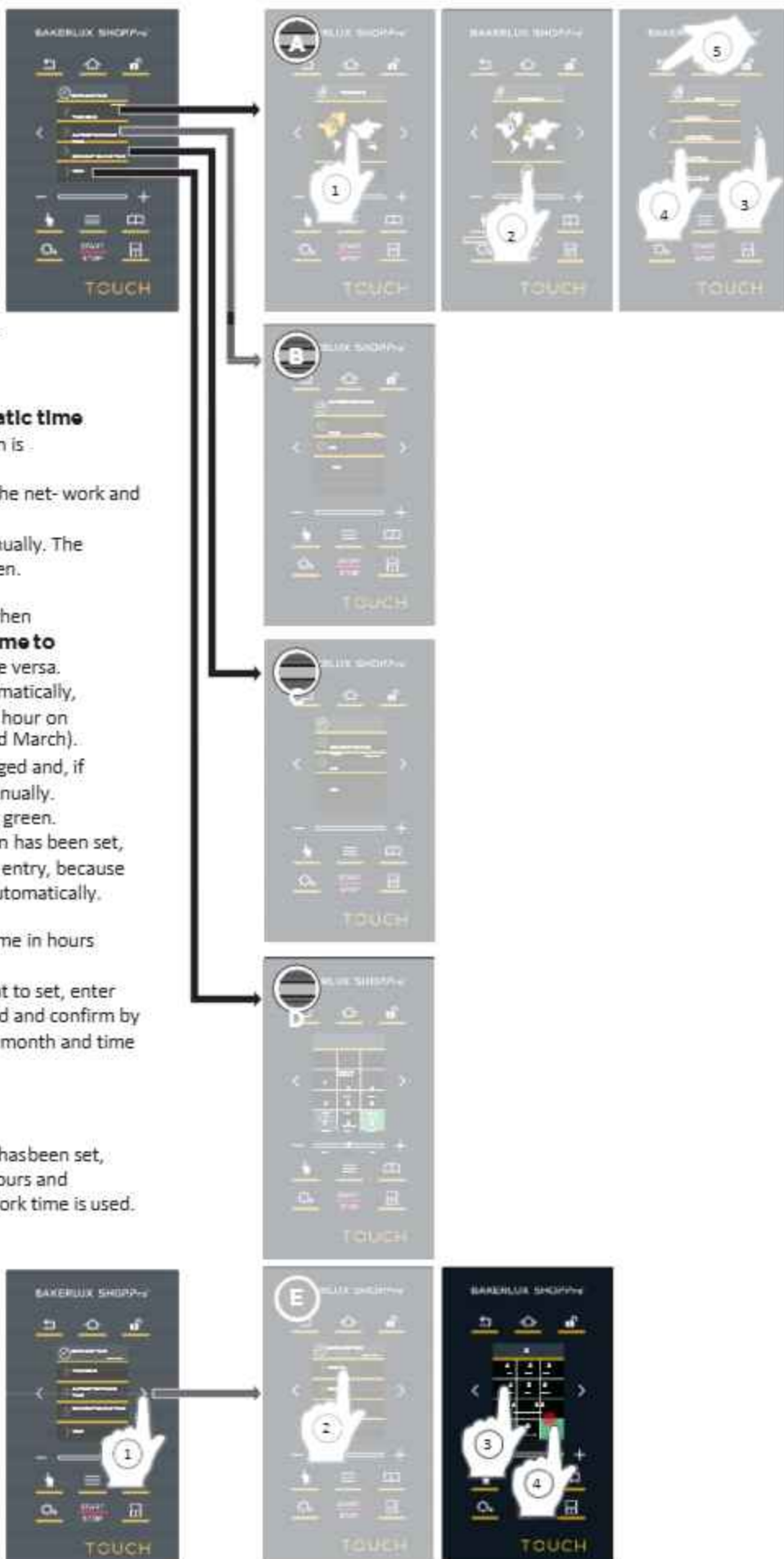



## BUZZER

The following can be set:

● the **volume** of the beep at the end of the cooking/leavening cycle, choosing from: high, medium or low;

● the **duration** of the beep at the end of the cooking/leavening cycle in seconds. The value is set by pressing the "+" and "-" buttons until you reach the desired value, or using the "scroll" function by sliding your finger over the bar. Using the scroll function is quicker. Confirm the value entered by pressing

ing ;

● **ON** or **OFF** for the optional external beep, where installed;

● **YES** or **NO** for the oven beep. If you choose "NO", when a cooking/leavening cycle finishes the oven will not beep to notify you.

The selected entries are highlighted in green.

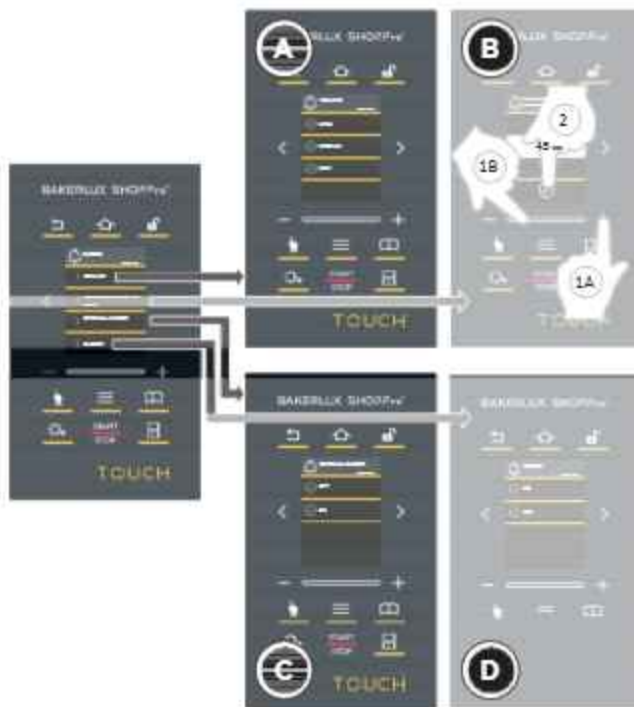

## AUTOMATIC DOOR

The following can be set:

- if you have an oven with an automatic door **(YES)**;
- if you DO NOT have an oven with an automatic door **(NO)**.



## 6

### LOCKING

This is used to lock some of the oven functions:

**A Lock cookbook:** this locks the option to modify saved recipes or to save new recipes ("YES" highlighted in green: lock activated);

**B Lock cooking:** this locks the option to modify a manual or automatic cooking cycle in progress ("YES" highlighted in green: lock activated);

**C Disable add time:** this disables the option to add extra time to completed cooking/leavening cycles ("YES" lit up green: lock activated);

**D Force preheating:** starts preheating (even if not set) up to the temperature of the first cooking step ("YES" highlighted in green: preheating is activated);

### PASSWORD PROTECTION

Prevent a cooking cycle from being starting without entering a password. To set the password:

- 1 use the > symbol;
- 2 select "SAFE LOCK";
- 3 select "ON", highlighting it green;
- 4 exit the menu by tapping the "go BACK" icon;
- 5 select "SAFE LOCK PIN";
- 6 enter the desired password using the keypad and confirm with "OK".

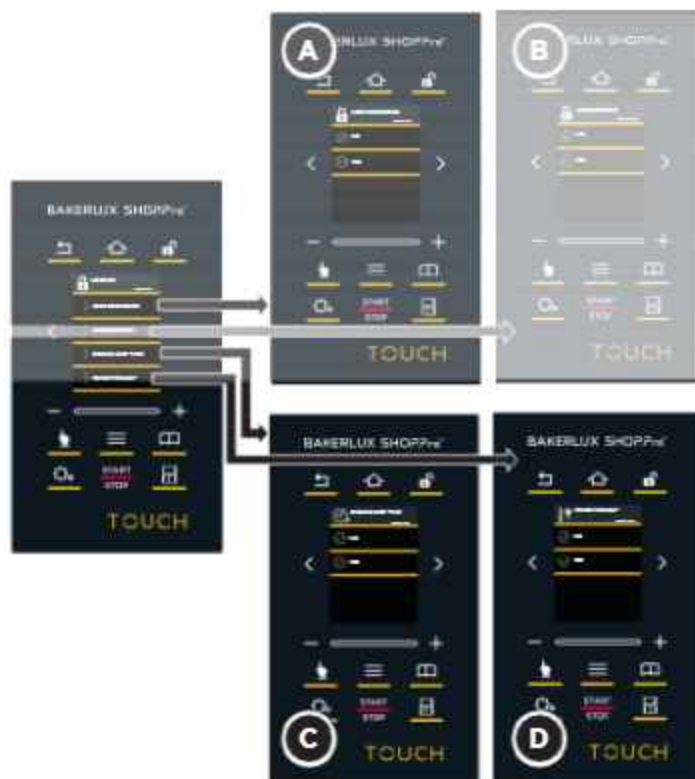

### Password protection



## 7 DEFAULT PROGRAM

If enabled, a default program can be run simply by pressing the "START/STOP" icon, without entering any cooking parameters before.

### Default program specifications:

duration: continuous



temperature: it is set in this same menu once, then it does not need to be set again. fan speed: 2

If this function is active, the SET menus are disabled (manual cooking settings), as well as PROGRAMS (saved recipes).

Once the cooking cycle has begun, the user can only modify the temperature, humidity and fan speed (see "Setting cooking parameters" on page 8).

To stop continuous operation, simply press the "START/STOP" icon.

### Activating the function and setting the temperature

- 1 2 Select the function;
- 3 select "ON", highlighting it green;
- 4 exit the screen by tapping the "GO BACK" icon 
- 5 Select the "Temperature" function;
- 6 Setting the desired temperature: to set the value, press the "+" and "-" buttons until you reach the desired value, or use the "scroll" function by sliding your finger over the bar. Using the scroll function is quicker.
- 7 Confirm the value entered with : all of the cooking cycles will have this temperature; you do not need to set it every time the cycle is started.

- 8 exit the screen by tapping the "GO BACK" icon 



## 8 FAST COOKBOOK START

With the function activated, if the oven operates continuously, you can access the cookbook quickly during a cooking cycle by pressing

the "PROGRAMS" icon 

## 9 IMPORT/EXPORT PROGRAMS

This section allows you to import or export material from your own USB stick (FT32 formatted and with capacity between 4 GB and 16 GB).

- EXPORT PROGRAMS: exports recipes from the oven to a USB stick;
- IMPORT PROGRAMS: exports recipes from a USB stick to the oven;
- IMPORT PICTURE: imports images from the USB stick to the oven, for example a photo of one of your successful dishes. The images must be converted before they can be used. Follow the procedure shown in the drawing, point ① to ⑦.



SETTINGS

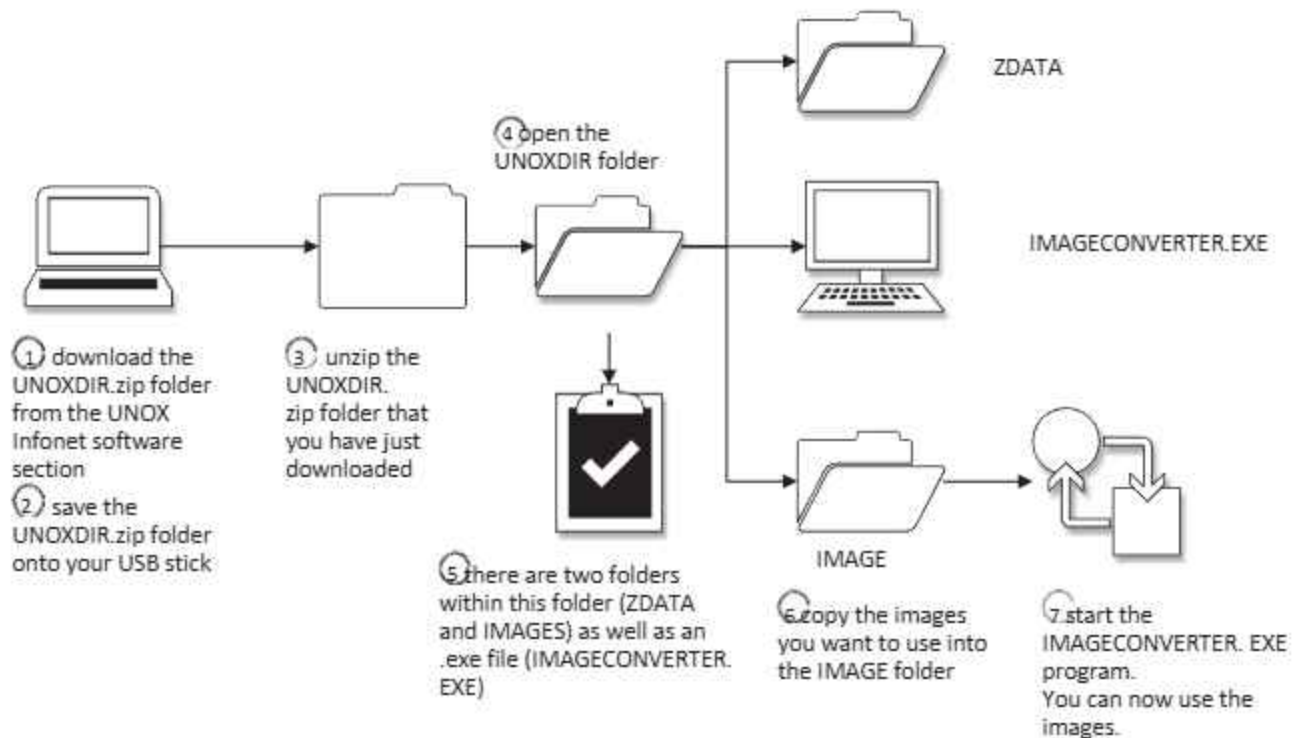



## UNOX.CARE

The filters reduce the temporary hardness of the drinking water caused by carbonates, thus preventing limescale deposits building up in the connected distribution equipment.

1 Tap "UNOX.Care" and a menu opens where you can:

- 2 3 4 **set/modify the water hardness** (range from 4 German °dH to 35 German °dH). Hardness is measured using the kit provided with the oven and is inserted/modified by pressing the "+" and "-" buttons until you reach the desired value, or using the "scroll" function by sliding your finger over the bar. Using the scroll function is quicker.

Confirm the value entered with ;

- 5 6 7 after replacing the old filter with a new one, **reset the litre counter** so that it starts counting from zero again. To carry out this operation, use the keypad to enter the PIN code identified on the new filter kit box (e.g.

12345) and confirm with .

8 Enter the PIN code for the new filter, which the oven recognises, and then, thanks to an internal litre counter (which has to be reset each time the filter is changed), the user can view, at any given moment, the **name of the filter installed** (e.g. BAKERY.PURE) and **how many litres of inlet water remain** until the filter will next need changing (REMAININGVOLUME).

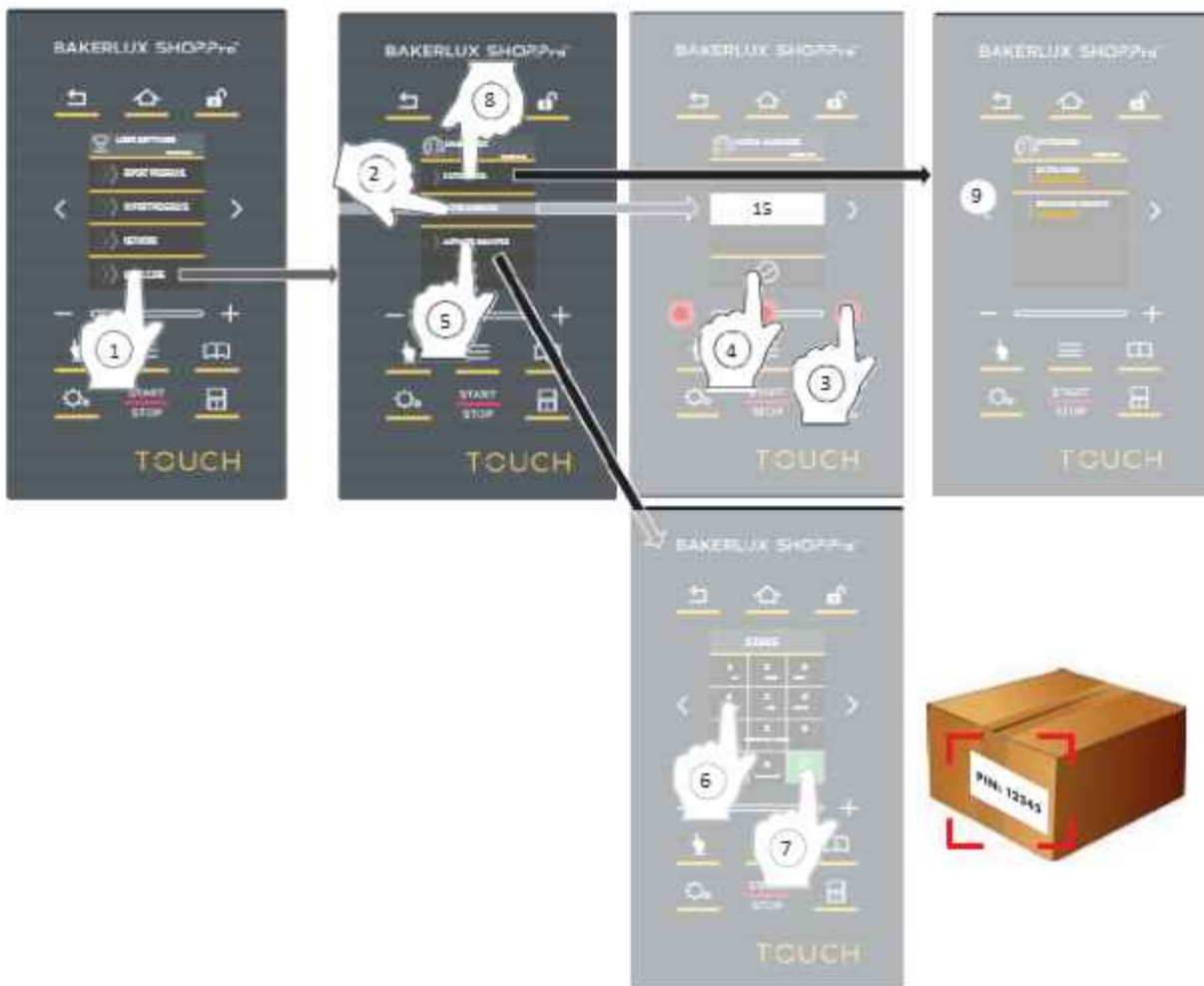



## HACCP DATA

HACCP data can be used by the user to monitor the processing of foods for which there is a risk of biological, chemical or physical contamination. More specifically, every 30 seconds the following readings are taken:

- oven cavity temperature;
- temperature measured by the core probe;
- vacuum-seal (sous vide) probe temperature.

This section allows you to import the data from your own USB stick (FT32 formatted and with capacity between 4 GB and 16 GB).



SETTINGS



# BAKERLUX SHOP.Pro™ Touch

## Alarms

The ovens show any alarm/warning messages relating to the oven or installed accessories on the screen. The warning messages signal malfunctions that allow the appliance/accessories to continue operating, but with a restricted set of functions.

The alarm messages (ALARM) identify issues that prevent any operation whatsoever of the appliances/ accessories, which therefore must be put into STOP mode.

If the alarm messages refer to the connected accessories, the oven can still be used.

<b>AF - OVEN ALARMS</b>			
<b>Display</b>	<b>Description</b>	<b>Effect</b>	<b>Solution</b>
AF01	Motor thermal alarm	The oven stops any operating cycle and blocks any screen display configuration	Contact the Customer Assistance Service
AF02	Safety thermostat alarm		
AF03	Oven cavity alarm		
AF04	Communications failure alarm		

<b>WF - OVEN WARNING</b>			
<b>Display</b>	<b>Description</b>	<b>Effect</b>	<b>Solution</b>
WF06	Warning: power board temperature	The oven will continue to operate, but humidity detection is disabled	
WF28	Warning: control board temperature	The oven continues to run	
WF33	SD card error	The oven continues to run	

<b>WC - COOKER HOOD WARNING</b>			
<b>Display</b>	<b>Description</b>	<b>Effect</b>	<b>Solution</b>
WC01	Smoke detector 1 broken	Smoke hood solenoid valve does not open when a smoke temperature probe is missing	Contact the Customer Assistance Service
WC02	Board temperature error	The hood continues to operate	
WC05	Inlet fumes too hot	The hood continues to operate	
WC07	Communication lost	Motor and smoke hood disengaged	Check the hood power cable; if the problem persists, contact the Customer Assistance Service

<b>AL - PROVER ALARM</b>			
<b>Display</b>	<b>Description</b>	<b>Effect</b>	<b>Solution</b>
AL01	Cavity probe alarm	The prover stops any operating cycle and blocks any screen display configuration	Contact the Customer Assistance Service
AL02	Communications failure alarm		

<b>WL - PROVER WARNING</b>			
<b>Display</b>	<b>Description</b>	<b>Effect</b>	<b>Solution</b>
WL02	Board temperature error	The prover continues to run	



# BAKERLUX SHOP.Pro™ Touch

## Ordinary and after-sales maintenance

-  **Any routine maintenance procedure must be performed:**
- **after disconnecting the appliance from the power and water supplies**
  - **after having put on the proper personal protective equipment (gloves, etc.).**

Clean the oven cavity daily to maintain proper levels of hygiene and to keep the stainless steel inside the oven cavity from becoming damaged or corroding.

When cleaning any component or accessory NEVER use:

- abrasive or powder detergents;
- aggressive or corrosive detergents (e.g. hydrochloric/muriatic or sulphuric acid). Caution! Never use these substances when cleaning the appliance substructure or the floor under the appliance;
- abrasive or sharp tools (abrasive sponges, scrapers, steel bristled brushes, etc.);
- water jets.

### EXTERNAL STEEL STRUCTURES, OVEN CAVITY SEAL

**Wait for the surfaces to cool off.**

Use only a soft cleaning cloth dampened with a little soap and water. Rinse and dry completely.

### INSIDE OF THE OVEN CAVITY

-  **Failure to clean the oven cavity daily can cause the accumulated grease and food residues inside to catch fire – risk of fire!**

Clean the oven cavity **daily** to maintain high levels of hygiene and to preserve the steel and the performance of the equipment over time. Fat particles or food residues may also catch fire during cooking, causing damage to people and the equipment. Cleaning should always be carried out when the oven cavity is cold, using a soft cloth soaked in warm soapy water. Finish cleaning by rinsing and drying.

### PLASTIC SURFACES AND CONTROL PANEL

Use only a very soft cleaning cloth and a small amount of detergent for cleaning delicate surfaces. Follow the detergent manufacturer's instructions.

### OVEN DOOR INTERNAL AND EXTERNAL GLASS

**Wait for the glass to cool off.**

Use only a soft cleaning cloth dampened with a little soap and water or a specific glass cleaner. Rinse and dry completely.

-  **FOR OVENS WITH A FLAP DOOR: During normal cleaning operations, DONOT remove the internal glass as it may break.**

## AFTER-SALES ASSISTANCE

In case of any malfunctions, disconnect the appliance from its power and water supplies. Consult the solutions proposed in the table.

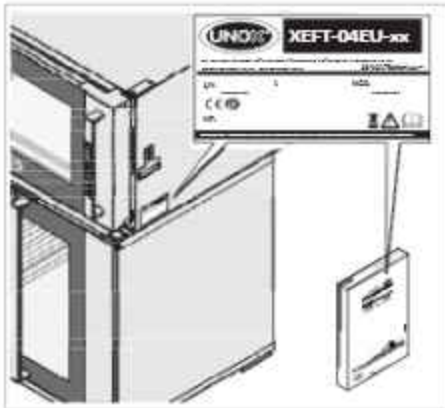

If the solution is not listed in the table, contact an UNOX-authorized technical service centre. Provide the following information:

- the date of purchase;
- the appliance data on the rating plate;
- any warning messages that appear on the display.

Manufacturer's information:

UNOX S.p.A.

Via Majorana, 22

35010 Cadoneghe (PD) Italy

Tel +39 049 86.57.511 - Fax +39 049 86.57.555

info@unox.com www.unox.com

Fault	Possible cause	Possible solution	Solution
The oven is completely switched off.	<ul style="list-style-type: none"> <li>- No mains power.</li> <li>- Appliance out of order.</li> </ul>	Make sure the appliance is connected to the electricity mains.	Contact the Customer Assistance Service.
No steam is produced inside the oven cavity.	<ul style="list-style-type: none"> <li>- Water inlet closed.</li> <li>- Appliance plumbed into the water mains or the tank incorrectly.</li> <li>- No water in the tank (if water is taken from the tank).</li> <li>- Water supply filter clogged with impurities.</li> </ul>	<ul style="list-style-type: none"> <li>- Open water inlet.</li> <li>- Make sure the appliance is plumbed into the water mains or the tank correctly.</li> <li>- Fill the tank with water.</li> <li>- Clean the filter.</li> </ul>	
After setting the time and pressing the "START/ STOP" button, the oven does not start.	Door open or not shut properly.	Make sure the door is shut.	
Water escapes from the seal when the door is shut.	<ul style="list-style-type: none"> <li>- Seal dirty.</li> <li>- Seal damaged.</li> <li>- The handle mechanism is loose.</li> </ul>	<ul style="list-style-type: none"> <li>- Clean the seal using a damp cloth.</li> <li>- Contact a specialised technician for repairs.</li> </ul>	

## INACTIVITY

During periods of inactivity, take the following precautions:

- disconnect the appliance from the power and water supplies;
- rub a soft cloth lightly doused with mineral oil on all stainless steel surfaces;
- keep the appliance door slightly ajar. Before

reusing the appliance:

- clean the appliance and accessories thoroughly (see page 33);
- reconnect the appliance to the power and water supplies;
- inspect the appliance before using it again;
- switch on the appliance at minimum temperature for 50 minutes without any food inside it.



To ensure that the appliance is in perfect condition in terms of use and safety, maintenance and inspections should be performed at least yearly by an authorised support service centre.

## DISPOSAL

Pursuant to Article 13 of Italian Legislative Decree no. 49 (2014) "Implementation of the WEEE Directive 2012/19/EU on electrical and electronic equipment waste":



The crossed-out wheeled bins symbol indicates that the product was placed on the market after 13 August 2005 and that, at the end of its useful life, it should not be disposed of with other waste, but must be collected separately.

All appliances are made with recyclable metal materials (stainless steel, iron, aluminium, galvanized steel, copper, etc.) in percentages above 90% by weight.

Before disposal, make the appliance unusable by removing the power cable and all compartment or cavity closure devices (where present).

At the end of its useful life, the product must be disposed of in such a way as to reduce any negative impact on the environment and make efficient use of available resources. Prefer prevention, preparation for reuse, recycling and reclamation, and remember "the polluter pays". Please remember that illegal or incorrect disposal of the product incurs penalties, as provided for by current legislation.

### Information on disposal in Italy

In Italy, WEEE appliances must be delivered to:

- recycling centres (also known as waste disposal sites/facilities)
- the dealer from whom a new appliance is purchased, who is required to collect them free of charge ("one-for-one" exchange);

### Information on disposal in European Union countries

The EU Directive on WEEE appliances has been implemented differently by each country. Therefore, if you want to dispose of this appliance, we recommend you contact your local authorities or dealer for information on the correct disposal method.

## CERTIFICATION

### EU declaration of conformity for electrical appliances

Manufacturer: UNOX S.p.A.

Address: Via Majorana, 22 - 35010 Cadoneghe, Padua, Italy declares, under its own responsibility, that the product **BAKERLUX**

**SHOP.Pro™**

complies with the Machinery Directive 2006/42/EC through the following standards: EN 60335-1: 2014 + A11:2014

EN 60335-2-42: 2003 + A1: 2008 + A11:2012

EN62233: 2008

EN 60335-2-102:2006 + A1:2010

complies with the Electromagnetic Compatibility Directive 2014/30/EC through the following standards: EN 55014-1: 2006 + A1: 2009 + A2: 2011

EN 55014-2: 1997 + A1: 2001 + A2: 2008

EN 61000-3-2: 2006 + A1: 2009 + A2: 2009

EN 61000-3-3: 2008

EN 61000-3-11: 2000

EN 61000-3-12: 2011

EN 61000-6-2: 2005

EN 61000-6-3: 2007