



BEVERAGE-AIR

Project: _____	AIA#
Item: _____	
Location: _____	SIS#
Approved: _____	

WTR41AHC SIDE MOUNT WORKTOP REFRIGERATOR

SIDE MOUNT WORKTOP WTR41AHC Solid Door Refrigerator Hydrocarbon Series

**MODEL:
WTR41AHC**



**5 Year Parts/Labor Warranty Available
7 Year Compressor Warranty**

CABINET CONSTRUCTION

- Stainless steel front, sides, door and grille (galvanized back & bottom)
- Interior liner is made of corrosion resistant aluminum
- Stainless steel top for added durability
- 16 Gauge stainless steel top
- Full electronic control
- Interior thermometer
- 4" Foamed-in-place backsplash
- Self-closing door with 120° stay-open feature
- Magnetic gasket attached to each door for positive seal
- 6" Casters, two (2) with brakes standard
- Two (2) epoxy-coated steel wire shelves
- Field-reversible door

OPTIONS & ACCESSORIES

- 3 Year parts/labor standard, additional 2 year warranty available
- Stainless steel back
- Stainless steel interior
- Additional shelves
- Shelf clips
- Right or left hinged door
- Door lock
- Wire shelf divider
- 3" Casters
- 6" Legs (stainless steel, black or seismic/flange)
- Low profile casters
- Roller kit
- Flat-top with no backsplash (-FLT)
- Remote option* (see note on back on page)

REFRIGERATION SYSTEM

- Uses environmentally friendly, energy efficient R290 refrigerant, and meets all regulatory requirements for CARB, SNAP, DOE & more
- Adaptive defrost
- Epoxy coated evaporator coil
- Refrigerators capable of maintaining product temperature between 36°F and 38°F



Please verify qualifying units by visiting:
www.energystar.gov/cfs

3779 Champion Blvd., Winston-Salem, NC 27105
1-888-845-9800 Fax: 1-336-245-6453
Beverage-Air.com Sales@bevair.com



BEVERAGE-AIR

Worktop Refrigerator - Side Mount Model: WTR41AHC

MODEL	WTR41AHC
EXTERNAL DIMENSIONAL DATA	
Width Overall	41"
Depth Overall with Handle & Bumper	35 3/4"
Height Overall with 6" Casters	39 1/2"
Number of Doors	1
Depth with Door Open 90°	57 1/8"
Door Opening	21 5/8" x 23 1/2"
INTERNAL DIMENSIONAL DATA	
NET Capacity (cubic ft.)	7.94
Internal Width Overall (in)	37"
Internal Depth Overall (in)	26"
Internal Height Overall (in)	25"
Number of Shelves	2
ELECTRICAL DATA	
Full Load Amperes	2.0
REFRIGERATION DATA	
Horsepower	1/6
Capacity (BTU/Hr)	1350
Heat Rejection (BTU/Hr)	2025
Charge (lbs/grams/ounces)	0.243 / 110 / 3.9
SHIPPING DATA	
Gross Weight - Crated	290 lbs
Height - Crated	44"
Width - Crated	44"
Depth - Crated	35"

*NOTE: Remote units are field wired and come with 6" legs.
Refrigerant must be specified at time of order.

Model Views

Required Clearance: 3" Bottom & 2" Rear

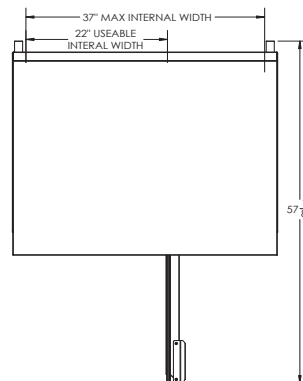

PLAN VIEW

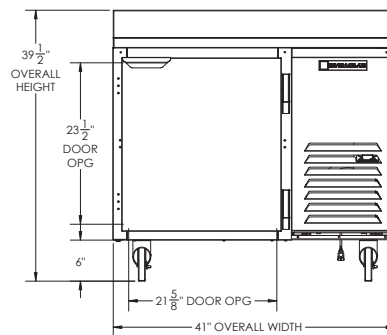

ELEVATION VIEW

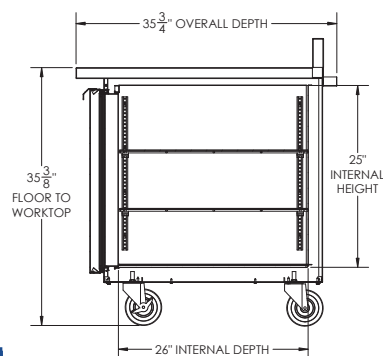

SIDE VIEW

ELECTRICAL CONNECTION



115/60/1
NEMA 5-15P

Unit pre-wired at factory
and include 8' long cord
and plug set.

