



BEVERAGE-AIR

Project: _____	AIA#
Item: _____	
Location: _____	SIS#
Approved: _____	

WTR36AHC WORKTOP REFRIGERATOR

WORKTOP REFRIGERATOR

WTR36AHC Solid Door With Flat Top Hydrocarbon Series

MODEL:
WTR36AHC-FLT



5 Year Parts/Labor Warranty Available
7 Year Compressor Warranty

CABINET CONSTRUCTION

- Stainless steel front, sides, doors and grille (galvanized back & bottom)
- Interior liner is made of corrosion resistant aluminum
- Stainless steel top for added durability
- Flat top
- Full electronic control
- Interior thermometer is standard
- Self-closing doors with 120° stay-open feature, on cartridge style hinges
- Magnetic gasket attached to each door for positive seal
- 6" Casters, two (2) with brakes standard
- Four (4) epoxy-coated steel wire shelves
- Field-reversible doors (hinge kit not included)

OPTIONS & ACCESSORIES

- 3 Year parts/labor standard, additional 2 year warranty available
- Stainless steel back
- Stainless steel interior
- 16 Gauge stainless steel top
- Additional shelves
- Shelf clips
- Glass door option
- Right or left hinged door
- Locks (solid doors only)
- Wire shelf divider
- Cutting board
- 3" Casters
- 6" Legs (stainless steel, black or seismic/flange)
- Low profile casters
- Roller kit
- Remote option* (see note on back on page)

REFRIGERATION SYSTEM

- Uses environmentally friendly, energy efficient R290 refrigerant, and meets all regulatory requirements for CARB, SNAP, DOE & more
- Adaptive defrost
- Epoxy coated evaporator coil
- Refrigerators capable of maintaining product temperature between 36°F and 38°F



 Please verify qualifying units by visiting:
www.energystar.gov/cfs

3779 Champion Blvd., Winston-Salem, NC 27105
1-888-845-9800 Fax: 1-336-245-6453
Beverage-Air.com Sales@bevair.com



BEVERAGE-AIR

MODEL	WTR36AHC-FLT
EXTERNAL DIMENSIONAL DATA	
Width Overall	36"
Depth Overall with Handle & Bumper	32"
Height Overall with 6" Casters	35 5/8"
Number of Doors	2
Depth with Door Open 90°	46 1/4"
Door Openings	13 3/4" x 21 7/8"
INTERNAL DIMENSIONAL DATA	
NET Capacity (cubic ft.)	8.5
Internal Width Overall (in)	32"
Internal Depth Overall (in)	15 3/8"
Internal Height Overall (in)	23"
Number of Shelves	4
ELECTRICAL DATA	
Full Load Amperes	2.0
REFRIGERATION DATA	
Horsepower	1/6
Capacity (BTU/Hr)	994
Heat Rejection (BTU/Hr)	1491
Charge (lbs/grams/ounces)	0.2425 / 110 / 3.9
SHIPPING DATA	
Gross Weight - Crated	218 lbs
Height - Crated	44"
Width - Crated	39"
Depth - Crated	33"

*NOTE: Remote units are field wired and come with 6" legs. Refrigerant must be specified at time of order.

Worktop Refrigerator Model: WTR36AHC-FLT

Model Views

Required Clearance: 3" Bottom & 2" Rear

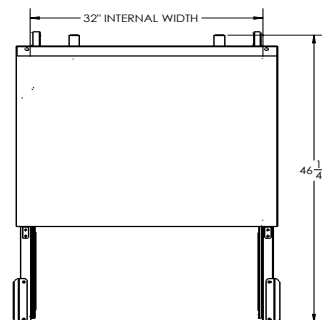

PLAN VIEW

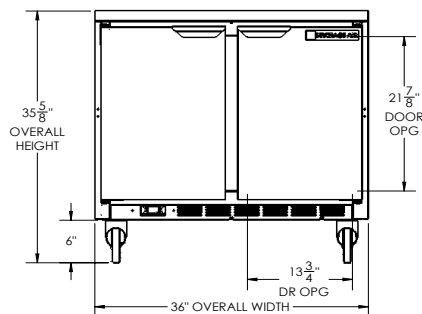

ELEVATION VIEW

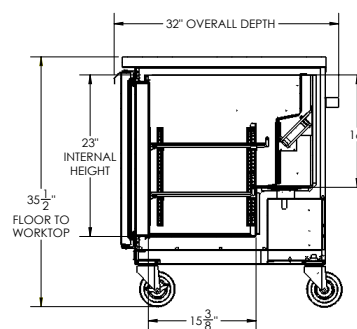

SIDE VIEW

ELECTRICAL CONNECTION



115/60/1
NEMA 5-15P

Unit pre-wired at factory and include 8' long cord and plug set.



3779 Champion Blvd., Winston-Salem, NC 27105 1-888-845-9800 Fax: 1-336-245-6453 Beverage-Air.com Sales@bevoir.com

an Ali Group Company



The Spirit of Excellence