



# BEVERAGE-AIR®

Project: _____	AIA#
Item: _____	SIS#
Location: _____	
Approved: _____	

**WTFD32AHC WORKTOP FREEZER**

## WORKTOP FREEZER

### WTFD32AHC Worktop Freezer With Drawers Hydrocarbon Series

**MODEL:  
WTFD32AHC-2**



**5 Year Parts/Labor Warranty Available  
7 Year Compressor Warranty**

#### CABINET CONSTRUCTION

- Stainless steel front, sides, drawers and grille (galvanized back & bottom)
- Interior liner is made of corrosion resistant aluminum
- Stainless steel worktop for added durability
- 4" Removable backsplash for flexibility and ease of cleaning
- Full electronic control
- Interior thermometer is standard
- Snap-in drawer gaskets
- Upper and lower pull-out drawers accommodate 6" deep pans
- Stainless steel drawer frames supported on telescoping drawer slides
- Drawer slides include locking mechanism that prevents drawer from being inadvertently pulled off cabinet
- 6" Casters, (2) with brakes standard

#### OPTIONS & ACCESSORIES

- 3 Year parts/labor standard, additional 2 year warranty available
- Stainless steel back
- Stainless steel interior
- 16 Gauge stainless steel top
- Cutting board
- 3" Casters
- 6" Legs (stainless steel, black or seismic/flange)
- Low profile casters
- Roller kit
- Remote option\* (see note on back on page)

#### REFRIGERATION SYSTEM

- Uses environmentally friendly, energy efficient R290 refrigerant, and meets all regulatory requirements for CARB, SNAP, DOE & more
- Adaptive defrost
- Epoxy coated evaporator coil
- Freezers capable of maintaining product temperature of -10°F



  
Please verify qualifying units by visiting:  
[www.energystar.gov/cfs](http://www.energystar.gov/cfs)

3779 Champion Blvd., Winston-Salem, NC 27105  
1-888-845-9800 Fax: 1-336-245-6453  
Beverage-Air.com Sales@bevair.com



# BEVERAGE-AIR

MODEL	WTFD32AHC-2
<b>EXTERNAL DIMENSIONAL DATA</b>	
Width Overall	32"
Depth Overall with Handle & Bumper	32"
Height Overall with 6" Casters	39 1/2"
Number of Drawers	2
Depth with Drawer Extended	48 1/2"
Drawer Openings	(2) 27 5/8" x 9 3/8"
<b>INTERNAL DIMENSIONAL DATA</b>	
NET Capacity (cubic ft.)	7.2
Internal Width Overall (in)	28"
Internal Depth Overall (in)	15 3/8"
Internal Height Overall (in)	23"
<b>ELECTRICAL DATA</b>	
Full Load Amperes	4.0
<b>REFRIGERATION DATA</b>	
Horsepower	1/3+
Capacity (BTU/Hr)	1184
Heat Rejection (BTU/Hr)	1776
Charge (lbs/grams/ounces)	0.165 / 75 / 2.64
<b>SHIPPING DATA</b>	
Gross Weight - Crated	232 lbs
Height - Crated	35"
Width - Crated	35"
Depth - Crated	33"

\*NOTE: Remote units are field wired and come with 6" legs.  
Refrigerant must be specified at time of order.

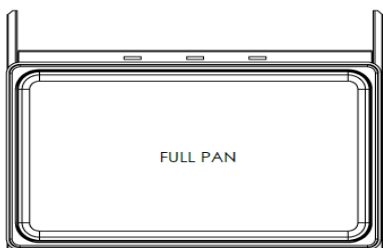

## Worktop Freezer With Drawers Model: WTFD32AHC-2

### Model Views

Required Clearance: 3" Bottom & 2" Rear

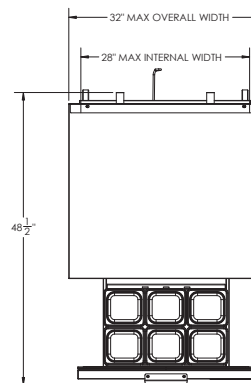

### PLAN VIEW

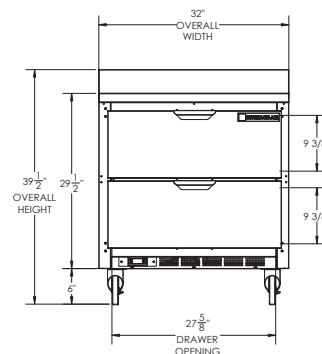

### ELEVATION VIEW

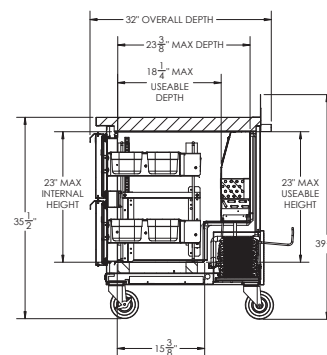

### SIDE VIEW

### ELECTRICAL CONNECTION



115/60/1  
NEMA 5-15P

Unit pre-wired at factory  
and include 8' long cord  
and plug set.

