



BEVERAGE-AIR®

Project: _____	AIA#
Item: _____	SIS#
Location: _____	
Approved: _____	

WTF27HC WORKTOP FREEZER

SHALLOW DEPTH WORKTOP

WTF27HC Solid Door With Foamed-In Place Backsplash Hydrocarbon Series

MODEL:
WTF27HC-FIP

5 Year Parts/Labor Warranty Available
7 Year Compressor Warranty



CABINET CONSTRUCTION

- Stainless steel front, sides, door and grille (galvanized back & bottom)
- Interior liner is made of corrosion resistant aluminum
- Stainless steel top for added durability
- Foamed-place backsplash
- Full electronic control
- Interior thermometer is standard
- Self-closing door with 120° stay-open feature, on cartridge style hinges
- Door opening includes low wattage, anti-condensate heaters
- Magnetic gasket attached to each door for positive seal
- 6" Casters, two (2) with brakes standard
- Two (2) epoxy-coated steel wire shelves
- Field-reversible door

OPTIONS & ACCESSORIES

- 3 Year parts/labor standard, additional 2 year warranty available
- Stainless steel back
- Stainless steel interior
- 16 Gauge stainless steel top
- Additional shelves
- Shelf clips
- Glass door option
- Right or left hinged door
- Locks (solid doors only)
- Bun rack
- Wire shelf divider
- 3" Casters
- 6" Legs (stainless steel, black or seismic/flange)
- Low profile casters
- Roller kit
- Remote option* (see note on back on page)

REFRIGERATION SYSTEM

- Uses environmentally friendly, energy efficient R290 refrigerant, and meets all regulatory requirements for CARB, SNAP, DOE & more
- Adaptive defrost
- Epoxy coated evaporator coil
- Freezers capable of maintaining product temperature of -10°F



Please verify qualifying units by visiting:
www.energystar.gov/cfs

3779 Champion Blvd., Winston-Salem, NC 27105
1-888-845-9800 Fax: 1-336-245-6453
Beverage-Air.com Sales@bevair.com



BEVERAGE-AIR

MODEL	WTF27HC-FIP
EXTERNAL DIMENSIONAL DATA	
Width Overall	27"
Depth Overall with Handle & Bumper	29 ⁷ / ₈ "
Height Overall with 6" Casters	39 ⁵ / ₈ "
Number of Doors	1
Depth with Door Open 90°	53 ¹ / ₈ "
Door Opening	22 ⁵ / ₈ " x 21 ⁵ / ₈ "
INTERNAL DIMENSIONAL DATA	
NET Capacity (cubic ft.)	5.25
Internal Width Overall (in)	23"
Internal Depth Overall (in)	13 ¹ / ₈ "
Internal Height Overall (in)	23"
Number of Shelves	2
ELECTRICAL DATA	
Full Load Amperes	2.5
REFRIGERATION DATA	
Horsepower	1/4
Capacity (BTU/Hr)	857
Heat Rejection (BTU/Hr)	1285.5
Charge (lbs/grams/ounces)	0.0992 / 45 / 1.59
SHIPPING DATA	
Gross Weight - Crated	192 lbs
Height - Crated	43"
Width - Crated	30"
Depth - Crated	32"

*NOTE: Remote units are field wired and come with 6" legs.
Refrigerant must be specified at time of order.

Worktop Freezer - Shallow Depth Model: WTF27HC-FIP

Model Views

Required Clearance: 3" Bottom & 2" Rear

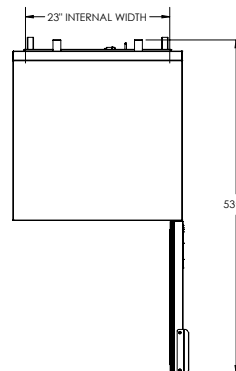

PLAN VIEW

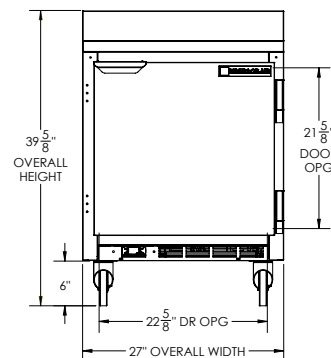

ELEVATION VIEW

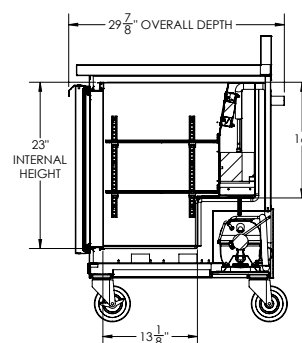

SIDE VIEW



ELECTRICAL CONNECTION



115/60/1
NEMA 5-15P

Unit pre-wired at factory
and include 8' long cord
and plug set.