



# BEVERAGE-AIR

Project: _____	AIA#
Item: _____	
Location: _____	SIS#
Approved: _____	

**WTF20HC WORKTOP FREEZER**

## SHALLOW DEPTH WORKTOP

WTF20HC Solid Door With Foamed-In Place Backsplash  
Hydrocarbon Series

MODEL:  
WTF20HC-FIP



**5 Year Parts/Labor Warranty Available**  
**7 Year Compressor Warranty**

### CABINET CONSTRUCTION

- Stainless steel front, sides, door and grille (galvanized back & bottom)
- Interior liner is made of corrosion resistant aluminum
- Stainless steel top for added durability
- Foamed-in place backsplash
- Full electronic control
- Interior thermometer is standard
- Self-closing door with 120° stay-open feature, on cartridge style hinges
- Door opening includes low wattage, anti-condensate heaters
- Magnetic gasket attached to each door for positive seal
- 6" Casters, two (2) with brakes standard
- Two (2) epoxy-coated steel wire shelves
- Field-reversible door (hinge kit not included)

### OPTIONS & ACCESSORIES

- 3 Year parts/labor standard, additional 2 year warranty available
- Stainless steel back
- Stainless steel interior
- 16 Gauge stainless steel top
- Additional shelves
- Shelf clips
- Glass door option
- Right or left hinged door
- Locks (solid doors only)
- Bun rack
- Wire shelf divider
- 3" Casters
- 6" Legs (stainless steel, black or seismic/flange)
- Low profile casters
- Roller kit
- Remote option\* (see note on back on page)

### REFRIGERATION SYSTEM

- Uses environmentally friendly, energy efficient R290 refrigerant, and meets all regulatory requirements for CARB, SNAP, DOE & more
- Adaptive defrost
- Epoxy coated evaporator coil
- Freezers capable of maintaining product temperature of -10°F



  
Please verify qualifying units by visiting:  
[www.energystar.gov/cfs](http://www.energystar.gov/cfs)

3779 Champion Blvd., Winston-Salem, NC 27105  
1-888-845-9800 Fax: 1-336-245-6453  
Beverage-Air.com Sales@bevair.com



# BEVERAGE-AIR

MODEL	WTF20HC-FIP
<b>EXTERNAL DIMENSIONAL DATA</b>	
Width Overall	20"
Depth Overall with Handle & Bumper	24 1/2"
Height Overall with 6" Casters	36 1/8"
Number of Doors	1
Depth with Door Open 90°	40 3/4"
Door Opening	15 5/8" x 18 1/8"
<b>INTERNAL DIMENSIONAL DATA</b>	
NET Capacity (cubic ft.)	2.34
Internal Width Overall (in)	16"
Internal Depth Overall (in)	8 1/4"
Internal Height Overall (in)	19 1/2"
Number of Shelves	2
<b>ELECTRICAL DATA</b>	
Full Load Amperes	2.5
<b>REFRIGERATION DATA</b>	
Horsepower	1/4
Capacity (BTU/Hr)	857
Heat Rejection (BTU/Hr)	1285.5
Charge (lbs/grams/ounces)	0.0992 / 45 / 1.59
<b>SHIPPING DATA</b>	
Gross Weight - Crated	134 lbs
Height - Crated	35"
Width - Crated	23"
Depth - Crated	26"

\*NOTE: Remote units are field wired and come with 6" legs.  
Refrigerant must be specified at time of order.

## Worktop Freezer - Shallow Depth Model: WTF20HC-FIP

### Model Views

Required Clearance: 3" Bottom & 2" Rear

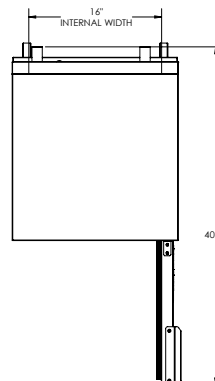

### PLAN VIEW

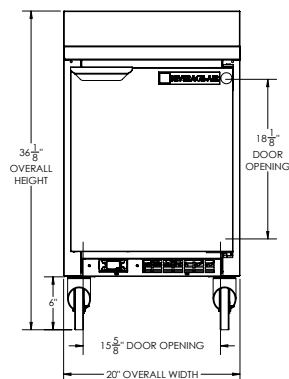

### ELEVATION VIEW

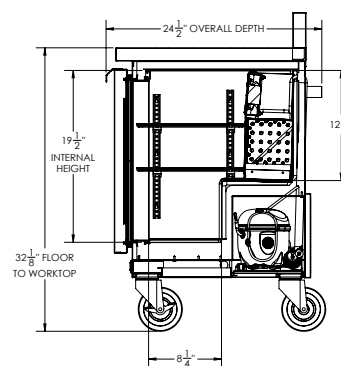

### SIDE VIEW

### ELECTRICAL CONNECTION



115/60/1  
NEMA 5-15P

Unit pre-wired at factory  
and include 8' long cord  
and plug set.

