



BEVERAGE-AIR®

Project: _____	AIA#
Item: _____	
Location: _____	SIS#
Approved: _____	

UCF32AHC UNDERCOUNTER FREEZER

UNDERCOUNTER FREEZER

UCF32AHC Solid Door Freezer

Hydrocarbon Series

MODEL:
UCF32AHC



5 Year Parts/Labor Warranty Available
7 Year Compressor Warranty

CABINET CONSTRUCTION

- Stainless steel front, sides, top, door and grille (galvanized steel back & bottom)
- Interior liner is made of corrosion resistant aluminum
- Full electronic control
- Undercounter feature a 1/2" thick sub-top
- Interior thermometer is standard
- Self-closing door with 120° stay-open feature, on cartridge style hinges
- Door opening includes low wattage, anti-condensate heater
- Magnetic gasket attached to each door for positive seal
- 6" Casters, two (2) with brakes standard
- Two (2) epoxy-coated steel wire shelves
- Field-reversible door (hinge kit not included)

OPTIONS & ACCESSORIES

- 3 Year parts/labor standard, additional 2 year warranty available
- Stainless steel back
- Stainless steel interior
- Right or left hinged door
- Additional shelves
- Shelf clips
- Glass door option
- Lock
- Wire shelf divider
- 3" Casters
- 6" Legs (stainless steel, black or seismic/flange)
- Low profile casters
- Roller kit
- Remote option* (see note on back on page)

REFRIGERATION SYSTEM

- Uses environmentally friendly, energy efficient R290 refrigerant, and meets all regulatory requirements for CARB, SNAP, DOE & more
- Adaptive defrost
- Epoxy coated evaporator coil
- Freezers capable of maintaining product temperature of -10°F



Please verify qualifying units by visiting:
www.energystar.gov/cfs

3779 Champion Blvd., Winston-Salem, NC 27105
1-888-845-9800 Fax: 1-336-245-6453
Beverage-Air.com Sales@bevair.com



BEVERAGE-AIR

MODEL	UCF32AHC
EXTERNAL DIMENSIONAL DATA	
Width Overall	32"
Depth Overall with Handle & Bumper	32"
Height Overall with 6" Casters	34 5/8"
Number of Doors	1
Depth with Door Open 90°	60 1/8"
Door Opening	27 5/8" x 21 5/8"
INTERNAL DIMENSIONAL DATA	
NET Capacity (cubic ft.)	7.2
Internal Width Overall (in)	28"
Internal Depth Overall (in)	18 1/4"
Internal Height Overall (in)	23"
Number of Shelves	2
ELECTRICAL DATA	
Full Load Amperes	4.0
REFRIGERATION DATA	
Horsepower	1/3+
Capacity (BTU/Hr)	1184
Heat Rejection (BTU/Hr)	1776
Charge (lbs/grams/ounces)	0.165 / 75 / 2.64
SHIPPING DATA	
Gross Weight - Crated	186 lbs
Height - Crated	34"
Width - Crated	32"
Depth - Crated	35"

*NOTE: Remote units are field wired and come with 6" legs.
Refrigerant must be specified at time of order.

Undercounter Freezer Model: UCF32AHC

Model Views

Required Clearance: 3" Bottom & 2" Rear

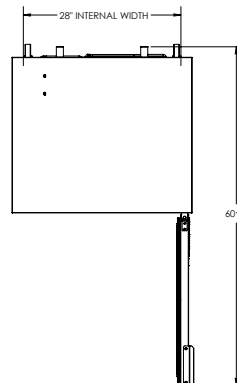

PLAN VIEW

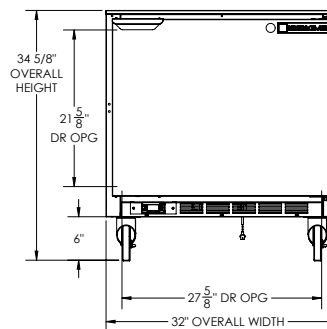

ELEVATION VIEW

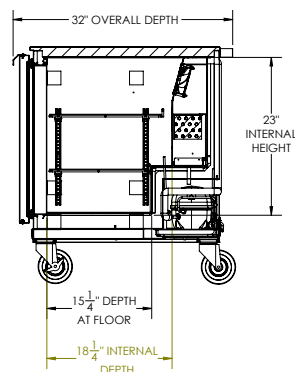

SIDE VIEW

ELECTRICAL CONNECTION



115/60/1
NEMA 5-15P

Unit pre-wired at factory and include 8' long cord and plug set.

