



TRUE MANUFACTURING CO., INC.  
U.S.A. FOODSERVICE DIVISION

2001 East Terra Lane • O'Fallon, Missouri 63366-4434 • (636)240-2400  
Fax (636)272-2408 • Toll Free (800)325-6152 • Intl Fax# (001)636-272-7546  
Parts Dept. (800)424-TRUE • Parts Dept. Fax# (636)272-9471 • www.truemfg.com

Project Name: \_\_\_\_\_

Location: \_\_\_\_\_

Item #: \_\_\_\_\_ Qty: \_\_\_\_\_

Model #: \_\_\_\_\_

A/A #

SIS #

Model:

TS-72FG-HC~FGD01

TS Series:

Reach-In Glass Swing Door Stainless Steel Freezer with Hydrocarbon Refrigerant~Framed Glass Door Version 01



## TS-72FG-HC~FGD01

- ▶ True's TS series is the choice for the exclusive stainless steel commercial application.
- ▶ Designed using the highest quality materials and components to provide the user with colder product temperatures, lower utility costs, exceptional food safety and the best value in today's food service marketplace.
- ▶ Factory engineered, self-contained, capillary tube system using environmentally friendly R290 hydro carbon refrigerant that has zero (0) ozone depletion potential (ODP), & three (3) global warming potential (GWP).
- ▶ High capacity, factory balanced refrigeration system that maintains -10°F (-23.3°C) temperatures. Ideal for both frozen foods and ice cream.
- ▶ Stainless steel interior and exterior front and sides. The very finest stainless with higher tensile strength for fewer dents and scratches. Matching aluminum back.
- ▶ Triple pane thermal glass door.
- ▶ Adjustable, heavy duty PVC coated gray shelves.
- ▶ Positive seal self-closing doors. Lifetime guaranteed door hinges and torsion type closure system.
- ▶ Automatic defrost system time-initiated, temperature-terminated. Saves energy consumption and provides shortest possible defrost cycle.

### Bottom mounted units feature:

- ▶ "No stoop" lower shelf.
- ▶ Storage on top of cabinet.
- ▶ Compressor performs in coolest, most grease free area of kitchen.
- ▶ Easily accessible condenser coil for cleaning.

## ROUGH-IN DATA

Specifications subject to change without notice.  
Chart dimensions rounded up to the nearest 1/8" (millimeters rounded up to next whole number).

| Model            | Doors | Shelves | Cabinet Dimensions (inches) (mm) |               |                | HP         | Voltage  | Amps        | NEMA Config. | Cord Length (total ft.) (total m) | Crated Weight (lbs.) (kg) |
|------------------|-------|---------|----------------------------------|---------------|----------------|------------|----------|-------------|--------------|-----------------------------------|---------------------------|
|                  |       |         | W                                | D†            | H*             |            |          |             |              |                                   |                           |
| TS-72FG-HC~FGD01 | 3     | 9       | 78 1/8<br>1985                   | 29 3/4<br>756 | 78 3/8<br>1991 | 3/4<br>N/A | 115/60/1 | 13.0<br>N/A | 5-20P        | 9<br>2.74                         | 760<br>345                |

† Depth does not include 1 3/8" (35 mm) for door handle.

\* Height does not include 5" (127 mm) for castors or 6" (153 mm) for optional legs.

Note: Requires 115/208-230/60Hz, single phase, 20 amp dedicated outlet.



APPROVALS:

AVAILABLE AT:

Model:  
TS-72FG-HC~FGD01

**TS Series:**  
Reach-In Glass Swing Door Stainless Steel Freezer with  
Hydrocarbon Refrigerant~Framed Glass Door Version 01



## STANDARD FEATURES

### DESIGN

- True's glass door reach-in's are designed with enduring quality that protects your long term investment.
- True's commitment to using the highest quality materials and oversized refrigeration systems provides the user with colder product temperatures, lower utility costs, exceptional food safety and the best value in today's food service marketplace.

### REFRIGERATION SYSTEM

- Factory engineered, self-contained, capillary tube system using environmentally friendly R290 hydro carbon refrigerant that has zero (0) ozone depletion potential (ODP), & three (3) global warming potential (GWP).
- High capacity, factory balanced refrigeration system that maintains -10°F (-23.3°C) temperatures. Ideal for both frozen foods and ice cream.
- State of the art, electronically commutated evaporator and condenser fan motors. ECM motors operate at higher peak efficiencies and move a more consistent volume of air which produces less heat, reduces energy consumption and provides greater motor reliability.
- Bottom mounted condensing unit positioned for easy cleaning. Compressor runs in coolest and most grease free area of the kitchen. Allows for storage area on top of unit.
- Automatic defrost system time-initiated, temperature-terminated. Saves energy consumption and provides shortest possible defrost cycle.

### CABINET CONSTRUCTION

- Exterior - Stainless steel front and sides. Corrosion resistant GalFan coated steel back.
- Interior - Stainless steel liner and floor.
- Insulation - entire cabinet structure is foamed-in-place using a high density, polyurethane insulation that has zero ozone depletion potential (ODP) and zero global warming potential (GWP).
- Welded, heavy duty steel frame rail, black powder coated for corrosion protection.
- Frame rail fitted with 4" (102 mm) diameter stem castors - locks provided on front set.

### DOORS

- Triple pane thermal glass assemblies with extruded aluminum frames. Door locks standard.
- Each door fitted with 15" (381 mm) long extruded aluminum handle.
- Positive seal self-closing doors. Lifetime guaranteed door hinges and torsion type closure system.
- Magnetic door gaskets of one piece construction, removable without tools for ease of cleaning.

### SHELVING

- Nine (9) adjustable, heavy duty PVC coated gray wire shelves 24 1/8" L x 22 3/8" D (613 mm x 591 mm). Four (4) chrome plated shelf clips included per shelf.
- Aluminum shelf support pilasters. Shelves are adjustable on 1/2" (13 mm) increments.

### LIGHTING

- LED interior lighting provides more even lighting throughout the cabinet. Safety shielded.

### MODEL FEATURES

- Evaporator is epoxy coated to eliminate the potential of corrosion.
- Exterior solar, digital temperature display.
- Rear airflow guards prevent product from blocking optimal airflow.
- NSF/ANSI Standard 7 compliant for open food product.

### ELECTRICAL

- Unit completely pre-wired at factory and ready for final connection to a 115/60/1 phase, 20 amp dedicated outlet. Cord and plug set included.



115/60/1  
NEMA-5-20R

### OPTIONAL FEATURES/ACCESSORIES

Upcharge and lead times may apply.

- 6" (153 mm) standard legs.
- 6" (153 mm) seismic/flanged legs.
- Alternate door hinging (factory installed).
- Novelty baskets.
- Additional shelves.
- Half door bun tray racks. Each holds up to eleven 18" L x 26" D (458 mm x 661 mm) sheet pans (sold separately) (airflow guards need to be removed).
- Full door bun tray racks. Each holds up to twenty-two 18" L x 26" D (458 mm x 661 mm) sheet pans (sold separately) (airflow guards need to be removed).

## PLAN VIEW

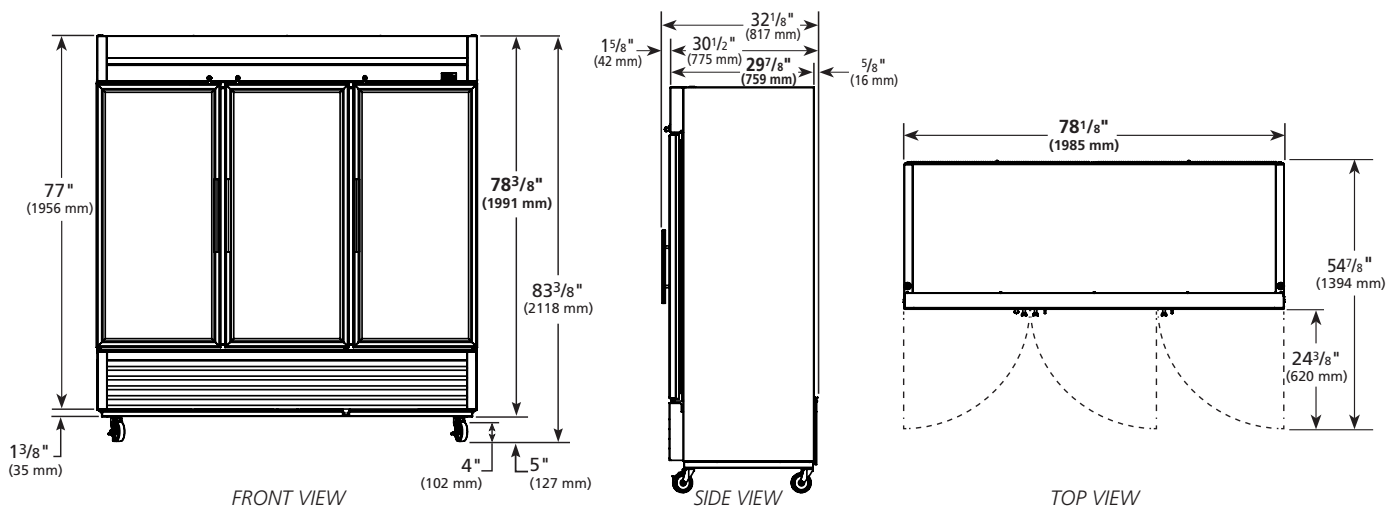

### WARRANTY

Three year warranty on all parts and labor and an additional 2 year warranty on compressor. (U.S.A. only)

METRIC DIMENSIONS ROUNDED UP TO THE NEAREST WHOLE MILLIMETER

SPECIFICATIONS SUBJECT TO CHANGE WITHOUT NOTICE



| Model            | Elevation | Right | Plan | 3D | Back |
|------------------|-----------|-------|------|----|------|
| TS-72FG-HC~FGD01 |           |       |      |    |      |

**TRUE MANUFACTURING CO., INC.**

2001 East Terra Lane • O'Fallon, Missouri 63366-4434 • (636)240-2400 • Fax (636)272-2408 • Toll Free (800)325-6152 • Intl. Fax# (001)636-272-7546 • www.truefmfg.com