



BEVERAGE-AIR

Project: _____	AIA#
Item: _____	
Location: _____	SIS#
Approved: _____	

STF58HC DUAL ACCESS, FORCED AIR: SCHOOL MILK SERIES

SCHOOL MILK FORCED AIR COOLER

STF58HC Dual Access Cooler
Hydrocarbon Series

MODEL:
STF58HC-1-W-02



5 Year Parts/Labor Warranty Available
7 Year Compressor Warranty

CABINET CONSTRUCTION

- White coated steel exterior
- Stainless steel interior
- Stainless steel lids, hinged doors and door latches
- Dual sided access
- Full electronic control
- Heavy-duty epoxy coated steel wire floor racks standard
- Floor drain is centrally located for easy cleaning and connecting to drain hose with hose adapter
- Flexible compression door gaskets, ensures a tight seal
- Self-latching doors/lids with safety bumpers
- Exterior thermometer
- Cylinder locks
- 5" Heavy-duty plate casters (2 with locks)
- Balanced, forced-air refrigeration system provides rapid chilling of product

OPTIONS & ACCESSORIES

- 3 Year parts/labor standard, additional 2 year warranty available
- Corner bumpers
- Cafeteria tray slides
- Graphics

REFRIGERATION SYSTEM

- Uses environmentally friendly, energy efficient R290 refrigerant, and meets all regulatory requirements for CARB, SNAP, DOE & more
- Maintains product temperature between 36°F- 40°F



Please verify qualifying units by visiting:
www.energystar.gov/cfs

3779 Champion Blvd., Winston-Salem, NC 27105
1-888-845-9800 Fax: 1-336-245-6453
Beverage-Air.com Sales@bevair.com



BEVERAGE-AIR

MODEL	STF58HC-1-W-02
EXTERNAL DIMENSIONAL DATA	
Width Overall	58"
Depth Overall	34"
Height Overall with Casters	47 3/4"
Number of Lids/Doors	Dual Access
Both Lids Extended	64"
INTERNAL DIMENSIONAL DATA	
NET Capacity (cubic ft.)	24.3
Internal Width Overall (in)	55"
Internal Depth Overall (in)	30"
Internal Height Overall (in)	24 5/8"
CASE CAPACITY	
13" X 13" X 11"	16
19" X 13" X 11"	10
ELECTRICAL DATA	
Full Load Amperes	2.46
REFRIGERATION DATA	
Horsepower	1/4
Capacity (BTU/Hr)	1851
Heat Rejection (BTU/Hr)	2776.5
Charge (lbs/grams/ounces)	0.1562 / 70 / 2.5
SHIPPING DATA	
Gross Weight - Crated	496 lbs
Height - Crated	54"
Width - Crated	63"
Depth - Crated	38"

School Milk Cooler - Dual Access Model: STF58HC-1-W-02

Model Views

Required Clearance: 4 3/4" bottom

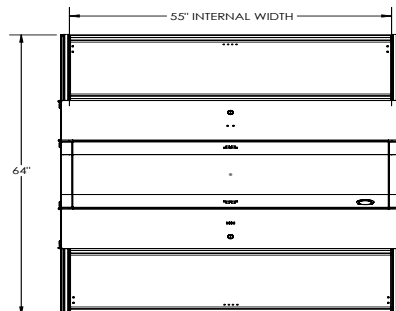

PLAN VIEW

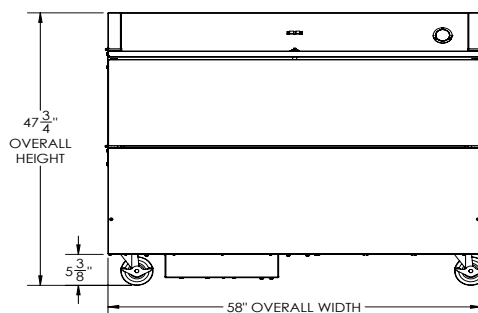

ELEVATION VIEW

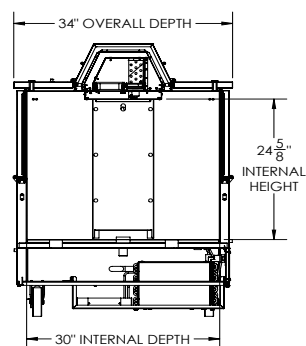

SIDE VIEW



ELECTRICAL CONNECTION



115/60/1
NEMA 5-15P

Unit pre-wired at factory
and include 8' long cord
and plug set.