



# BEVERAGE-AIR

Project: _____	AIA#
Item: _____	
Location: _____	SIS#
Approved: _____	

# SPED36HC SANDWICH PREP: MEGA TOP

## FOOD PREPARATION TABLES

### SPED36HC Sandwich Prep Table Mega Top with Drawers Hydrocarbon Series

**MODEL:**  
**SPED36HC-12M-2**



**5 Year Parts/Labor Warranty Available**  
**7 Year Compressor Warranty**

#### CABINET CONSTRUCTION

- Stainless steel front, sides, top, drawers, and grille (galvanized steel back & bottom)
- Interior liner is made of corrosion resistant aluminum
- Removable hoods made of matching stainless steel
- Full electronic control
- Mega top
- Airflow assures that product in open containers is kept below 41°F and above freezing
- Snap-in magnetic gaskets for positive drawer seal
- Painted aluminum drawer handles
- 10" Wide cutting board constructed of white polyethylene plastic
- Cutting board removable for cleaning
- 6" Casters, with (2) brakes standard
- Stainless steel drawer frames supported on telescoping drawer slides
- Drawer slides include locking mechanism that prevents drawers from being inadvertently pulled off cabinet
- Pans furnished are 4" deep constructed of polycarbonate plastic
- Twelve (12) 1/6 4" deep pans constructed of polycarbonate plastic

#### OPTIONS & ACCESSORIES

- 3 Year parts/labor standard, additional 2 year warranty available
- Stainless steel back
- Stainless steel interior
- Clear lid
- Overshelves (single or double)
- Crumb catcher kit
- Richlite cutting board
- Night cover
- Bottle organizer
- Pan supports
- Pan support crossbar
- 6" Legs or 3" casters
- Low profile casters
- Remote option\* (see note on back page)

#### REFRIGERATION SYSTEM

- Uses environmentally friendly, energy efficient R290 refrigerant, and meets all regulatory requirements for CARB, SNAP, DOE & more
- Adaptive defrost
- Epoxy coated evaporator coil
- Enhanced airflow maintains temperatures between 36° - 38°F



Please verify qualifying units by visiting:  
[www.energystar.gov/cfs](http://www.energystar.gov/cfs)

3779 Champion Blvd., Winston-Salem, NC 27105  
1-888-845-9800 Fax: 1-336-245-6453  
Beverage-Air.com Sales@bevair.com



# BEVERAGE-AIR

## Food Preparation Table: Mega Top with Drawers Model: SPED36HC-12M-2

MODEL	SPED36HC-12M-2
<b>EXTERNAL DIMENSIONAL DATA</b>	
Width Overall	36"
Depth Overall	38 3/8"
Height Overall with Casters	49"
No. of Drawers	2
Depth with Drawer Open 90°	48 1/2"
Drawer Openings	31 5/8" x 11 1/8" 31 5/8" x 7 1/2"
Width, Cutting Board	10"
<b>INTERNAL DIMENSIONAL DATA</b>	
NET Capacity (cubic ft.)	10.01
Internal Width Overall (in)	32"
Internal Depth Overall (in)	15 3/8"
Internal Height Overall (in)	23"
No. of Pans	12
<b>ELECTRICAL DATA</b>	
Full Load Amperes	2.0
<b>REFRIGERATION DATA</b>	
Horsepower	1/6
Capacity (BTU/Hr)	1140
Heat Rejection (BTU/Hr)	1710
Charge (lbs/grams)	0.243/110
<b>SHIPPING DATA</b>	
Gross Weight - Crated	300 lbs
Height - Crated	46"
Width - Crated	51"
Depth - Crated	33"

\*NOTE: Remote units are field wired and come with 6" legs.  
Refrigerant must be specified at time of order.

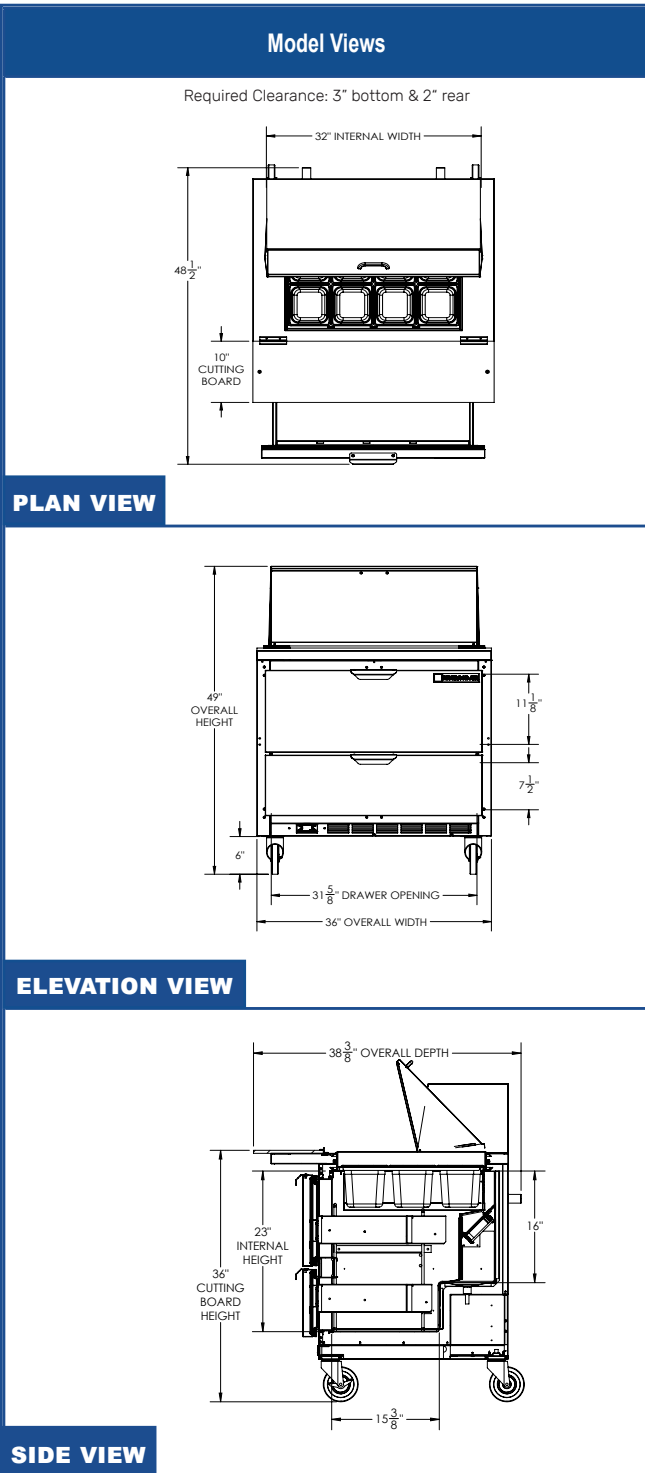
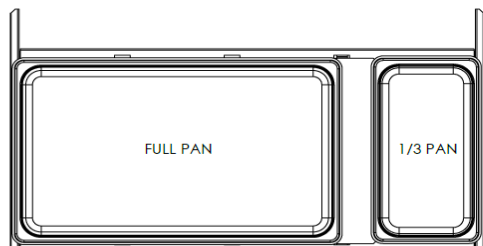

### ELECTRICAL CONNECTION

115/60/1  
NEMA 5-15P

Unit pre-wired at factory  
and include 8' long cord  
and plug set.