



# BEVERAGE-AIR

Project: _____	AIA#
Item: _____	
Location: _____	SIS#
Approved: _____	

# SPE36HC SALAD BAR

## FOOD PREPARATION TABLES

### SPE36HC Salad Bar

### Hydrocarbon Series

**MODEL:**  
**SPE36HC-S**

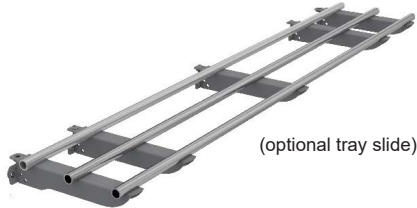

(optional tray slide)

**5 Year Parts/Labor Warranty Available**  
**7 Year Compressor Warranty**

### CABINET CONSTRUCTION

- Stainless steel front, sides, top, doors and grille (galvanized back & bottom)
- Interior liner is made of corrosion resistant aluminum
- Lift-off lid standard
- Heavy-duty aluminum pan liner, easy to clean and prevents spills from falling into cabinet while also ensuring coldest air flows across bottom of pans
- Six (6) 4" deep 1/3 size polycarbonate pans are included
- Accommodates up to 6" deep food service pans
- Locking divider bars
- Self-closing doors with 120° stay-open feature, on cartridge style hinges
- Easy door removal for service and cleaning
- Field-reversible doors with snap-in door gaskets
- 6" Casters, 2 with brakes
- Four (4) epoxy coated wire shelves

### OPTIONS & ACCESSORIES

- 3 Year parts/labor standard, additional 2 year warranty available
- Stainless steel exterior with finished back
- Stainless steel interior
- Sneeze guard panel for dual side service
- Sneeze guard panel for single side service
- Foldable tray slides
- Door locks
- 3" Casters or 6" legs
- Low profile casters
- Shelf dividers
- Pan supports

### REFRIGERATION SYSTEM

- Uses environmentally friendly, energy efficient R290 refrigerant, and meets all regulatory requirements for CARB, SNAP, DOE & more
- Adaptive defrost
- Epoxy coated evaporator coil
- Enhanced airflow maintains temperature between 36° to 38°F



Please verify qualifying units by visiting:  
[www.energystar.gov/cfs](http://www.energystar.gov/cfs)

3779 Champion Blvd., Winston-Salem, NC 27105  
1-888-845-9800 Fax: 1-336-245-6453  
Beverage-Air.com Sales@bevair.com



# BEVERAGE-AIR

MODEL	SPE36HC-S
<b>EXTERNAL DIMENSIONAL DATA</b>	
Width Overall	36 <sup>5</sup> / <sub>8</sub> "
Depth Overall	30 <sup>1</sup> / <sub>8</sub> "
Height Overall with Casters	36 <sup>13</sup> / <sub>16</sub> "
Number of Doors	2
Depth with Door Open Extended	44 <sup>3</sup> / <sub>8</sub> "
Door Openings (in)	13 <sup>9</sup> / <sub>16</sub> " x 21 <sup>9</sup> / <sub>16</sub> "
Number of Shelves	4
<b>INTERNAL DIMENSIONAL DATA</b>	
NET Capacity (cubic ft.)	10.01
<b>ELECTRICAL DATA</b>	
Full Load Amperes	2.0
<b>REFRIGERATION DATA</b>	
Horsepower	1/6
Capacity (BTU/Hr)	1094
Heat Rejection (BTU/Hr)	1641
Charge (lbs/grams/ounces)	0.2425 / 110 / 3.9
<b>SHIPPING DATA</b>	
Gross Weight - Crated	276 lbs
Height - Crated	47"
Width - Crated	39"
Depth - Crated	33"

## Salad Bar Model: SPE36HC-S

### Model Views

Required Clearance: 3" Bottom & 2" Rear

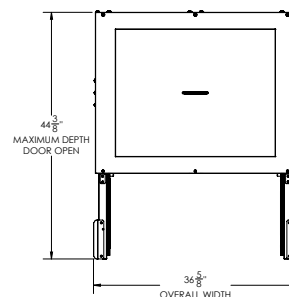

### PLAN VIEW

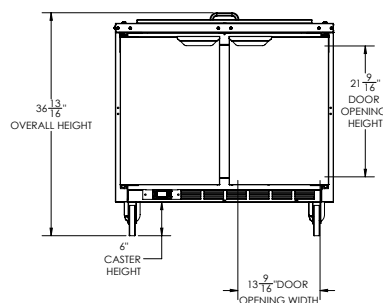

### ELEVATION VIEW

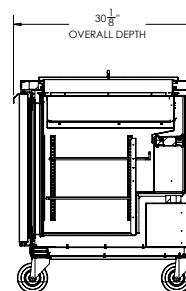

### SIDE VIEW

### ELECTRICAL CONNECTION



115/60/1  
NEMA 5-15P

Unit pre-wired at factory  
and include 8' long cord  
and plug set.



3779 Champion Blvd., Winston-Salem, NC 27105 1-888-845-9800 Fax: 1-336-245-6453 Beverage-Air.com Sales@bevoir.com

an Ali Group Company



The Spirit of Excellence