



# BEVERAGE-AIR

Project: _____	AIA#
Item: _____	
Location: _____	SIS#
Approved: _____	

## FOOD PREPARATION TABLES

### SPE36HC Sandwich Prep Table With 17" Cutting Board Hydrocarbon Series

MODEL:  
SPE36HC-10C

**SPE36HC SANDWICH PREP: CUT TOP SERIES**



**5 Year Parts/Labor Warranty Available**  
**7 Year Compressor Warranty**

#### CABINET CONSTRUCTION

- Stainless steel front, sides, top, doors and grille (galvanized back & bottom)
- Interior liner is made of corrosion resistant aluminum
- Full electronic control
- Cut top
- Airflow assures that product in open containers is kept below 41°F and above freezing
- Self-closing doors with 120° stay-open feature on cartridge style hinges
- Snap-in magnetic gaskets for positive door seal
- Painted aluminum door handles
- 6" Casters, 2 with brakes standard
- 17" Wide cutting board constructed of white polyethylene plastic
- Cutting board removable for cleaning
- Four (4) epoxy-coated steel wire shelves
- Ten (10) 1/6 4" deep pans constructed of polycarbonate plastic

#### OPTIONS & ACCESSORIES

- 3 Year parts/labor standard, additional 2 year warranty available
- Stainless steel back
- Stainless steel interior
- Left hinged door (at time of order)
- Door locks
- Overshelves (single or double)
- Crumb catcher
- Richlite cutting board
- Night cover
- Epoxy coated shelves
- Shelf clips
- Shelf dividers
- Bottle organizer
- Pan supports
- Pan support crossbar
- 6" Legs or 3" casters
- Low profile casters
- Remote option\* (see note on back page)

#### REFRIGERATION SYSTEM

- Uses environmentally friendly, energy efficient R290 refrigerant, and meets all regulatory requirements for CARB, SNAP, DOE & more
- Adaptive defrost
- Epoxy coated evaporator coil
- Enhanced airflow maintains temperatures between 36° - 38°F



Please verify qualifying units by visiting:  
[www.energystar.gov/cfs](http://www.energystar.gov/cfs)



3779 Champion Blvd., Winston-Salem, NC 27105  
1-888-845-9800 Fax: 1-336-245-6453  
Beverage-Air.com Sales@bevair.com



# BEVERAGE-AIR

MODEL	SPE36HC-10C
<b>EXTERNAL DIMENSIONAL DATA</b>	
Width Overall	36"
Depth Overall	38 1/4"
Height Overall with Casters	45"
No. of Doors	2
Depth with Door Open 90°	46 1/4"
Door Openings	13 3/4" x 21 7/8"
Width, Cutting Board	17"
<b>INTERNAL DIMENSIONAL DATA</b>	
NET Capacity (cubic ft.)	10.01
Internal Width Overall (in)	32"
Internal Depth Overall (in)	23 3/8"
Internal Height Usable (in)	23"
No. of Shelves	4
No. of Pans	10
<b>ELECTRICAL DATA</b>	
Full Load Amperes	2.0
<b>REFRIGERATION DATA</b>	
Horsepower	1/6
Capacity (BTU/Hr)	1140
Heat Rejection (BTU/Hr)	1710
Charge (lbs/grams)	0.243/110
<b>SHIPPING DATA</b>	
Gross Weight - Crated	238 lbs
Height - Crated	48"
Width - Crated	38"
Depth - Crated	38"

\*NOTE: Remote units are field wired and come with 6" legs.  
Refrigerant must be specified at time of order.

## Food Preparation Table: Cut Top Model: SPE36HC-10C

### Model Views

Required Clearance: 3" bottom & 2" rear

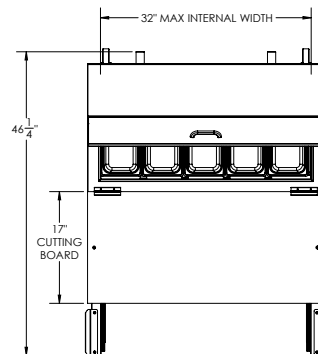

PLAN VIEW

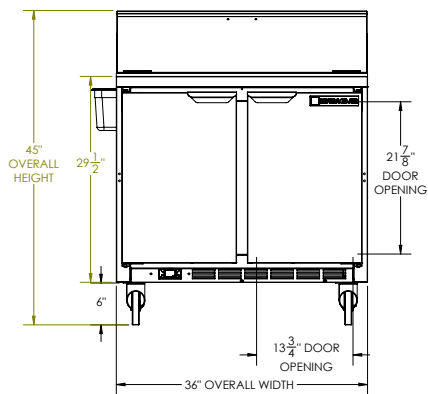

ELEVATION VIEW

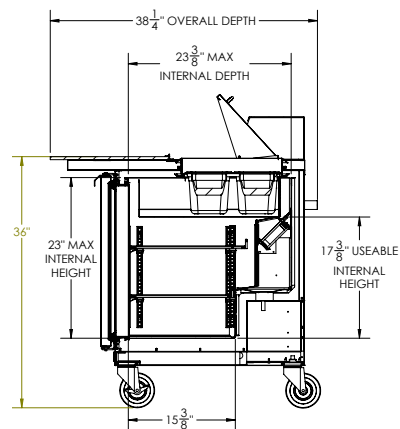

SIDE VIEW



### ELECTRICAL CONNECTION

115/60/1  
NEMA 5-15P

Unit pre-wired at factory  
and include 8' long cord  
and plug set.