

# SP48-18M-HC Mega Top Prep Table

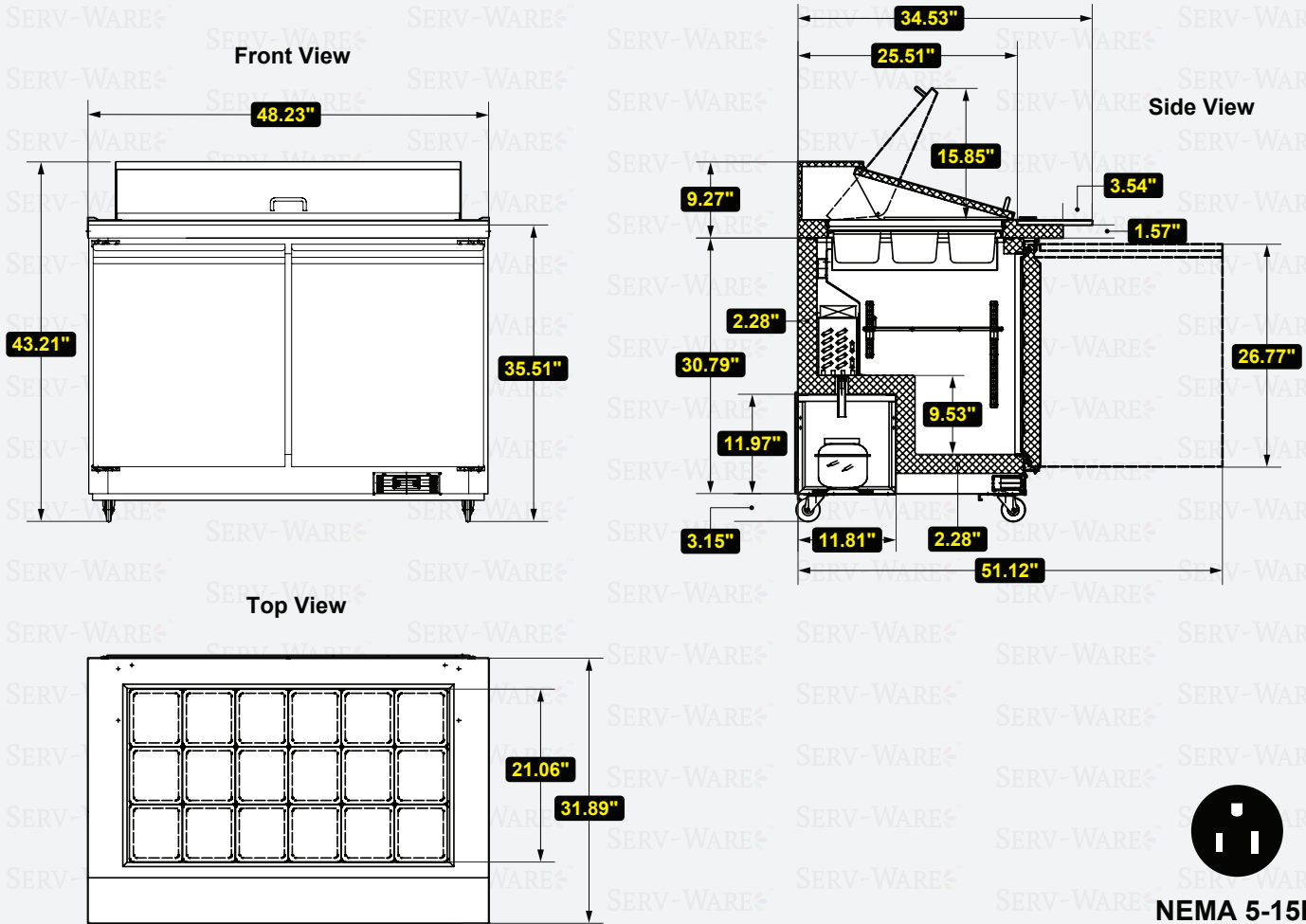

Item # \_\_\_\_\_  
 Project : \_\_\_\_\_  
 Qty : \_\_\_\_\_



**NEMA 5-15P**

**Technical Information:**

MODEL #	DESCRIPTION	DIMENSIONS	WEIGHT/LBS.
		(W x D x H)	(Shipping)
SP48-18M-HC	18 Pan Prep Unit	48.2" W x 29.9" D x 43.2" H	335 lbs.

CONSTRUCTION	
Exterior Material	Stainless Steel
Interior Material	ABS plastic w/ 304 S/S Floor
Insulation Material	CFC Free Foam
Shelf Material	Epoxy Coated Wire
Number of Shelves	1 per Door

COOLING	
Temperature Range	33°F – 41°F
Refrigerant+Charge oz.	R290 / 3.17 oz.
BTU/H	1365
Defrosting	Every 6 Hours
Horse Power	½
Storage Capacity	12 cu. ft.

ELECTRICAL	
Voltage	115
Amps	4.3
Hz	60
Phase	1

**ADDITIONAL INFORMATION**

*Installation by certified commercial restaurant equipment installer recommended. Inspection before and after installation by licensed electrician for safe operation. Product designed for interior usage in a climate controlled location with adequate air circulation and not adjacent to a high temperature source.*



Prop. 65 Warning for California Residents  
 WARNING: This product may contain chemicals known to the State of California to cause cancer, birth defects, or other reproductive harm.



Copyright © 2024 Serv-Ware Products LLC.

Phone:(800).768.5953  
 Fax:(800).976.1299

[www.servware.com](http://www.servware.com)

HOLE PUNCH ZONE

HOLE PUNCH ZONE