



# PORTABLE FILTER SYSTEM

- SBF14
- SBF18

### Typical Application

Mobile filtering of all of your frying appliances. Filter can be used with gravity drain fryers.

### Standard Features

- Filter pan and pump assembly enclosure are constructed of polished stainless steel. All other surfaces are nickel plated finish.
- Welded steel frame mounted on four ball-bearing swivel casters for easy movement.
- 1/3 HP heavy duty motor and pump assembly.
- 5 foot (1.5 meter) flexible, sanitary, high temperature return hose equipped with nozzle.
- Return hose nozzle is nickel plated steel with a non-heat conducting handle.
- Extra large filter area for large fryer filtering.
- 10 Foot oil proof supply cord.
- Comes standard with a filter pan, cover, filter catch basket, sample filter paper (flat), sample filter powder packets, (1) sediment clean out scoop, and (1) 7 inch drain nipple.



SBF14

### OPTIONS & ACCESSORIES AT ADDITIONAL COST

- Filter Powder Packets
- Filter Paper (flat)

### STANDARD CONSTRUCTION SPECIFICATIONS

#### Controls:

- ON/OFF switch for operating pump.

#### Operations:

- Four swivel caster design allows for easy movement and storage of the filter.
- Quick disconnect hose connections make it easy to assemble and disassemble.
- Low profile allows for easy placement under the fryer drain.
- Easy to remove filter media assembly for quick and easy filter paper replacement.
- Lift out filter pan for easy cleaning.



Approval Notes: \_\_\_\_\_

\_\_\_\_\_

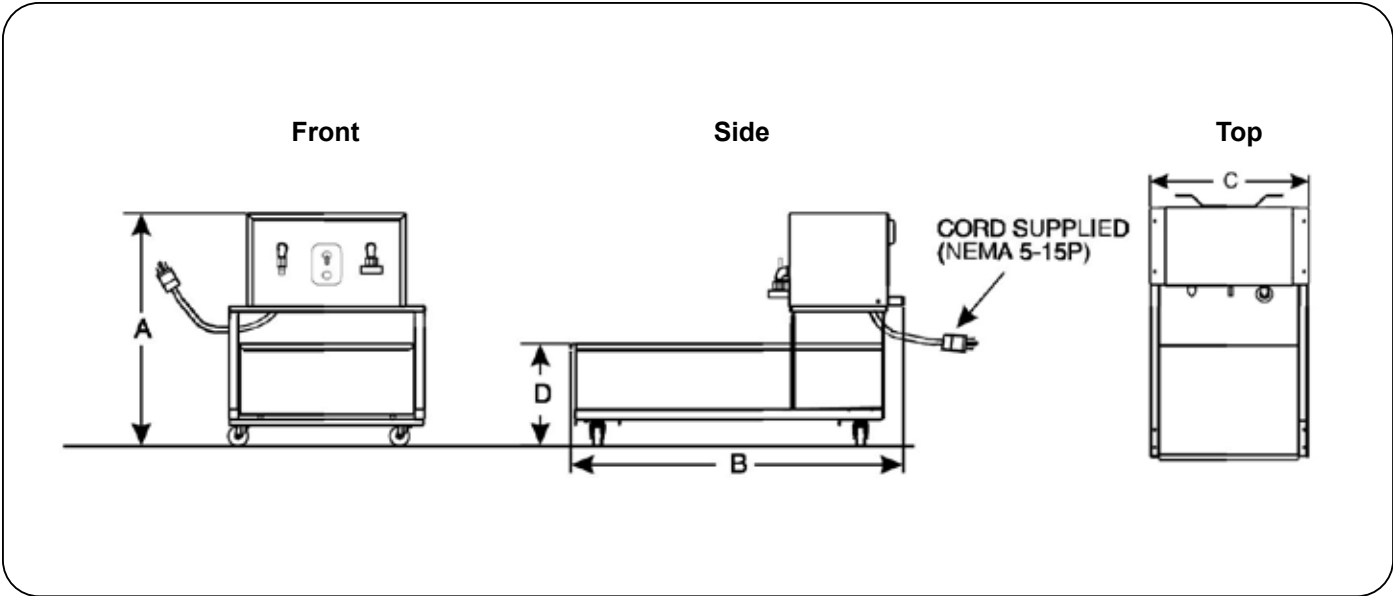

**DIMENSIONS**

MODEL	COMPATIBLE FRYERS	A	B	C	D	SHIPPING INFORMATION
SBF14	SB35S	24 in (61 cm)	30 in (76.2 cm)	17 in (43.2 cm)	10-1/2 in (28 cm)	131 lbs (59.4 Kg.) 10 cu. ft. (0.28 cu. meters)
	SB45S					
SBF18	SB65S	24 in (61 cm)	34 in (86.4 cm)	20-1/4 in (51.4 cm)	10-1/2 in (28 cm)	150 lbs (68.0 Kg.) 14 cu. ft. (0.40 cu. meters)

Dimensions shown in inches and (centimeters)

**UTILITY INFORMATION**

MODEL	PAN CAPACITY	PERFORMANCE CHARACTERISTICS	ELECTRICAL
SBF14	55 lbs (24.9 Kg.)	Pumps up to 5.6 gallons (21.2 liters) per minute.	120 VAC / 60 Hz / 10 AMP 220/240 VAC / 50 Hz / 4 AMP
SBF18	75 lbs (34.0 Kg.)		

Unit shall have the ability to receive oil gravity drained from fryers. Model SBF14 shall have 300 square inches (1,936 square cm) of filter area. Model SBF18 shall have 450 square inches (2,903 square cm) of filter area. Unit shall have a polished stainless steel filter pan and pump enclosure; all other surfaces to be nickel plated.

**MISCELLANEOUS**

- If using Flex-Hose, the I.D. should not be smaller than 3/4" and must comply with ANSI Z 21.69
- If casters are used with flex hose, a restraining device should be used to eliminate undue strain on the flex hose
- For installation on combustible floors (with 6" high legs) and adjacent to combustible walls, allow 6" clearance.
- Install under vented hood
- Check local codes for fire, installation and sanitary regulations.

**NOTICE:**

Southbend has a policy of continuous product research and improvement. We reserve the right to change specifications and product design without notice. Such revisions do not entitle the buyer to corresponding changes, improvements, additions or replacements for previously purchased equipment.

**INTENDED FOR COMMERCIAL USE ONLY.  
NOT FOR HOUSEHOLD USE.**

