



# BEVERAGE-AIR®

|                 |      |
|-----------------|------|
| Project: _____  | AIA# |
| Item: _____     |      |
| Location: _____ | SIS# |
| Approved: _____ |      |

**RB72HC BOTTOM MOUNT: VISTA® SERIES**

## VISTA® BOTTOM MOUNT REACH-IN REFRIGERATOR

**MODEL:**  
RB72HC-1G

RB72HC Glass Door Reach-In Refrigerator  
Hydrocarbon Series



**5 Year Parts/Labor Warranty Available**  
**7 Year Compressor Warranty**

### CABINET CONSTRUCTION

- Stainless steel front and grille, gray painted sides
- Gray painted aluminum interior
- Full electronic control
- LED lighting
- Self-closing doors with 120° stay-open feature, on spring-loaded hinges
- One-piece grille allow easy removal/installation for preventative maintenance
- Nine (9) heavy duty epoxy coated wire shelves standard
- 6" Casters standard with (2) brakes

### OPTIONS & ACCESSORIES

- 3 Year parts/labor standard, additional 2 year warranty available
- Stainless steel universal tray slides (AC)
- Epoxy shelves
- Shelf clips
- 3" Casters or 6" legs
- 6" Flanged/seismic feet
- Door Locks
- Remote option\* (see note on back page)

### REFRIGERATION SYSTEM

- Uses environmentally friendly, energy efficient R290 refrigerant, and meets all regulatory requirements for CARB, SNAP, DOE & more
- Adaptive defrost
- Epoxy coated evaporator coil
- Maintains product temperatures between 36°-38°F



 Please verify qualifying units by visiting:  
[www.energystar.gov/cfs](http://www.energystar.gov/cfs)

3779 Champion Blvd., Winston-Salem, NC 27105  
1-888-845-9800 Fax: 1-336-245-6453  
Beverage-Air.com Sales@bevair.com



# BEVERAGE-AIR®

| MODEL                            | RB72HC-1G           |
|----------------------------------|---------------------|
| <b>EXTERNAL DIMENSIONAL DATA</b> |                     |
| Width Overall                    | 75"                 |
| Depth Overall with Handle        | 33 ½"               |
| Height Overall                   | 84 ½"               |
| Number of Doors                  | 3                   |
| Depth with Door Open 90°         | 55 ½"               |
| Door Openings (in)               | 21 ⅞" x 52 ¾"       |
| <b>INTERNAL DIMENSIONAL DATA</b> |                     |
| NET Capacity (cubic ft.)         | 70.19               |
| Internal Width Overall (in)      | 72"                 |
| Internal Depth Overall (in)      | 28 ½"               |
| Internal Height Overall (in)     | 61 ¾"               |
| Internal Height Useable (in)     | 55"                 |
| Number of Shelves                | 9                   |
| <b>ELECTRICAL DATA</b>           |                     |
| Full Load Amperes 115/60/1       | 6.12                |
| <b>REFRIGERATION DATA</b>        |                     |
| Horsepower                       | 1/2                 |
| Capacity (BTU/Hr)                | 3628                |
| Heat Rejection (BTU/Hr)          | 5442                |
| Charge (lbs/grams/ounce)         | 0.2204 / 100 / 3.53 |
| <b>SHIPPING DATA</b>             |                     |
| Gross Weight (crated lbs)        | 696 lbs             |
| Height - Crated                  | 87"                 |
| Width - Crated                   | 77"                 |
| Depth - Crated                   | 36"                 |

\*NOTE: Remote units are field wired and come with 6" legs.  
Refrigerant must be specified at time of order.

## VISTA® Bottom Mount Reach-In Refrigerator Model: RB72HC-1G

### Model Views

Required Clearance: Rear 3" & Bottom 3"

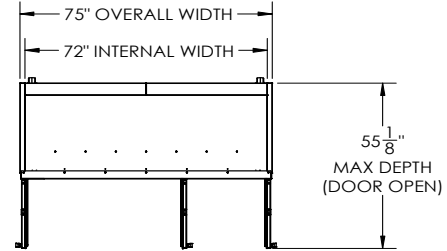

### PLAN VIEW

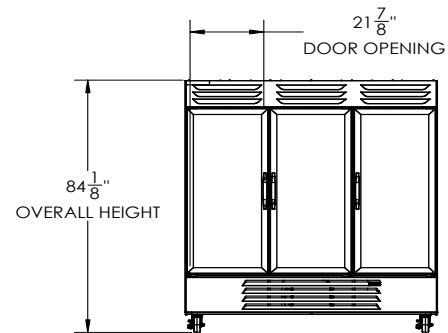

### ELEVATION VIEW

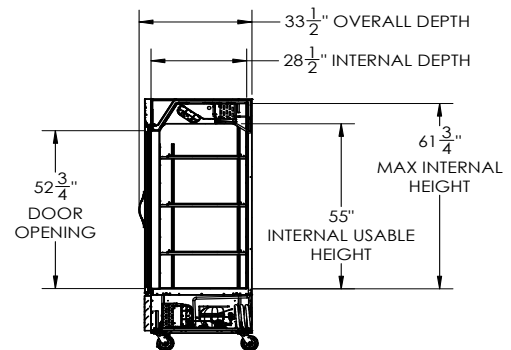

### SIDE VIEW

### ELECTRICAL CONNECTION



115/60/1  
NEMA 5-15P

Unit pre-wired at factory and include 8' long cord and plug set.



3779 Champion Blvd., Winston-Salem, NC 27105 1-888-845-9800 Fax: 1-336-245-6453 Beverage-Air.com Sales@bevoir.com

an Ali Group Company



The Spirit of Excellence