



BEVERAGE-AIR

Project: _____	AIA#
Item: _____	
Location: _____	SIS#
Approved: _____	

PRD2HC TOP MOUNT REFRIGERATOR: PASS-THRU

P SERIES TOP MOUNT REFRIGERATOR PASS-THRU

MODEL:
PRD2HC-1AHS

PRD2HC Solid-Half Door Reach-In
Hydrocarbon Series



5 Year Parts/Labor Warranty Available
7 Year Compressor Warranty

CABINET CONSTRUCTION

- Exterior stainless steel front and side (galvanized top, bottom & back)
- Interior is made of corrosion resistant aluminumV
- Stainless steel door liner
- Full electronic control
- Expansion valve technology
- Variable speed compressor technology
- Self-closing doors with 120° stay-open feature
- 22 Gauge stainless steel half door
- LED interior light
- Cylinder locks
- Snap-in magnetic gaskets for positive door seal
- Hinged front shroud
- Energy saving thermal breaker
- Stainless steel breaker caps
- Six (6) heavy-duty epoxy wire coated shelves
- 6" High adjustable stainless steel legs
- 8' Cord and plug (see electrical data for details)

OPTIONS & ACCESSORIES

- 3 Year parts/labor standard, additional 2 year warranty available
- Stainless steel interior
- Additional shelves
- Shelf clips
- 3" or 6" Casters
- 6" Seismic legs
- Tray slides (type A & A/C)
- Door swing orientation (at time of order)
- Remote option* (see note back on page)

REFRIGERATION SYSTEM

- Uses environmentally friendly, energy efficient R290 refrigerant, and meets all regulatory requirements for CARB, SNAP, DOE & more
- Adaptive defrost
- Epoxy coated evaporator coil, located out of the food zone
- Refrigerator capable of maintaining product temperature 36°F to 38°F



Please verify qualifying units by visiting:
www.energystar.gov/cfs

3779 Champion Blvd., Winston-Salem, NC 27105
1-888-845-9800 Fax: 1-336-245-6453
Beverage-Air.com Sales@bevair.com



BEVERAGE-AIR®

P Series Top Mount Refrigerator Pass-Thru Model: PRD2HC-1AHS

MODEL	PRD2HC-1AHS
EXTERNAL DIMENSIONAL DATA	
Width Overall	52 1/8"
Depth Overall with Handles	38 3/8"
Height Overall	84 1/8"
No. of Doors	8
Depth with Door Open 90°	84 1/4"
Door Openings	21 1/2" x 25 1/4"
INTERNAL DIMENSIONAL DATA	
NET Capacity (cubic ft.)	48.33
Internal Width Overall (in)	48 1/8"
Internal Depth Overall (in)	26"
Internal Height Overall (in)	56 3/8"
No. of Shelves	6
ELECTRICAL DATA	
Full Load Amperes 115/60/1**	6.5
REFRIGERATION DATA	
Horsepower	1/3
Capacity (BTU/Hr)	2800
Heat Rejection (BTU/Hr)	4200
Charge (lbs/grams/ounces)	0.3307 / 150 / 5.29
WEIGHT DATA	
Gross Weight - Crated	650 lbs
Height - Crated	88"
Width - Crated	60"
Depth - Crated	45"

*NOTE: Remote units are field wired and come with 6" legs.
Refrigerant must be specified at time of order.

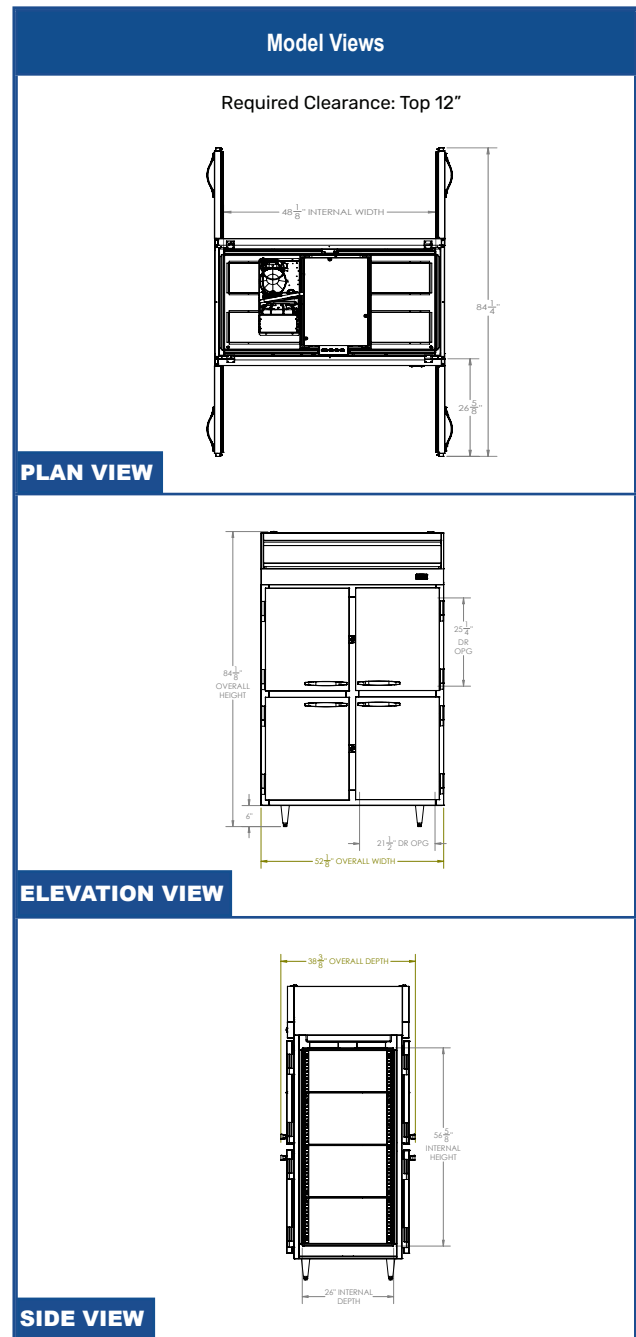

ELECTRICAL CONNECTION



115/60/1**
NEMA 5-15P

Unit pre-wired at factory
and include 8' long cord
and plug set.

** NOTE: This unit utilizes variable speed compressor technology. The compressor can experience nuisance tripping on Class A GFCI outlets which have a trip limit of 4 mA to 6 mA. To avoid this issue in a location that requires GFCI circuit protection, Beverage-Air recommends using a HUBBELL Model Number GFRST83W 20A Heavy Duty Hospital Grade Self-Test GFCI Receptacle.

