



**BEVERAGE-AIR**

Project: _____	AIA#
Item: _____	
Location: _____	SIS#
Approved: _____	

**PF2HC TOP MOUNT FREEZER**

**P SERIES TOP MOUNT FREEZER**

PF2HC Solid Door Reach-In  
Hydrocarbon Series

**MODEL:  
PF2HC-1AS**



**5 Year Parts/Labor Warranty Available  
7 Year Compressor Warranty**

**CABINET CONSTRUCTION**

- Exterior stainless steel front and side (galvanized top, bottom & back)
- Interior is made of corrosion resistant aluminum
- Stainless steel door liner
- Full electronic control
- Expansion valve technology
- Self-closing doors with 120° stay-open feature
- 22 Gauge stainless steel doors
- LED interior light
- Cylinder locks
- Snap-in magnetic gaskets for positive door seal
- Hinged front shroud
- Energy saving thermal breaker
- Stainless steel breaker caps
- Six (6) heavy-duty epoxy wire coated shelves
- 6" High adjustable stainless steel legs
- 8' Cord and plug (see electrical data for details)

**OPTIONS & ACCESSORIES**

- 3 Year parts/labor standard, additional 2 year warranty available
- Stainless steel case back
- Stainless steel interior
- Additional shelves
- 3" or 6" Casters
- 6" Seismic legs
- Tray slides (type A & A/C)
- Door swing orientation (at time of order)
- Remote option\* (see note back on page)

**REFRIGERATION SYSTEM**

- Uses environmentally friendly, energy efficient R290 refrigerant, and meets all regulatory requirements for CARB, SNAP, DOE & more
- Adaptive defrost
- Epoxy coated evaporator coil, located out of the food zone
- Freezer capable of maintaining product temperature down to -10°F



Please verify qualifying units by visiting:  
[www.energystar.gov/cfs](http://www.energystar.gov/cfs)

3779 Champion Blvd., Winston-Salem, NC 27105  
1-888-845-9800 Fax: 1-336-245-6453  
Beverage-Air.com Sales@bevair.com



# BEVERAGE-AIR®

MODEL	PF2HC-1AS
<b>EXTERNAL DIMENSIONAL DATA</b>	
Width Overall	52 1/8"
Depth Overall with Handles	34 7/8"
Height Overall	84 1/8"
Number of Doors	2
Depth with Door Open 90°	59 5/8"
Door Opening (in)	21 1/2" x 54 5/8"
<b>INTERNAL DIMENSIONAL DATA</b>	
NET Capacity (cubic ft.)	44.57
Internal Width Overall (in)	48 1/8"
Internal Depth Overall (in)	26"
Internal Height Overall (in)	56 5/8"
No. of Shelves	6
<b>ELECTRICAL DATA</b>	
Full Load Amperes 115/60/1	10.5
<b>REFRIGERATION DATA</b>	
Horsepower	3/4+
Capacity (BTU/Hr)	2580
Heat Rejection (BTU/Hr)	3870
Charge (lbs/grams/ounces)	0.2866 / 130 / 4.59
<b>SHIPPING DATA</b>	
Gross Weight (crated lbs)	552 lbs
Height - Crated	88"
Width - Crated	60"
Depth - Crated	45"

\*NOTE: Remote units are field wired and come with 6" legs.  
Refrigerant must be specified at time of order.

## P Series Top Mount Freezer Model: PF2HC-1AS

### Model Views

Required Clearance: Top 12"

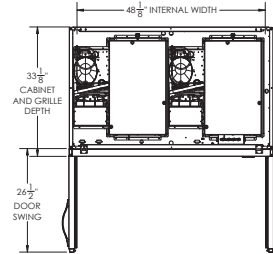

### PLAN VIEW

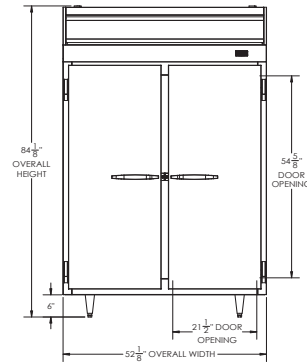

### ELEVATION VIEW

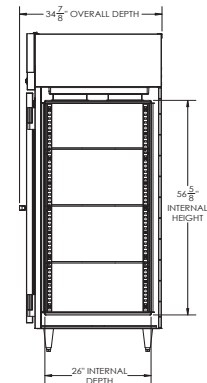

### SIDE VIEW



## ELECTRICAL CONNECTION



115/60/1  
NEMA 5-15P

Unit pre-wired at factory  
and include 8' long cord  
and plug set.