



# BEVERAGE-AIR

Project: _____	AIA#
Item: _____	
Location: _____	SIS#
Approved: _____	

**MMRF72HC GLASS DOOR MERCHANDISER SERIES - DUAL-TEMP**

## MARKETMAX DUAL-TEMP REFRIGERATOR/FREEZER

**MODEL:**  
MMRF72HC-1-C-WW

MMRF72HC White Hinged Triple Glass Door  
Hydrocarbon Series

**5 Year Parts/Labor Warranty Available**  
**7 Year Compressor Warranty**



### CABINET CONSTRUCTION

- Exterior features durable white painted steel
- Heavy duty interior construction includes white coated steel walls
- Brightly lit sign panel
- LED lighting
- Modern one-piece grille
- Full electronic control with digital display
- Dual-temp refrigerator/freezer units provide two different operating temperature zones for different types of products
- Self-contained bottom mount refrigeration system
- Left: refrigerator double section has double pane lowE glass doors
- Right: freezer single section has triple pane lowE glass door
- Self-closing doors with 120° stay-open feature
- Snap-in gaskets, easy to remove for cleaning or replacement
- Self-contained bottom mount refrigeration system
- Fifteen (15) heavy-duty epoxy coated wire shelves
- Four (4) shelf clips included per shelf
- Leveling feet standard

### OPTIONS & ACCESSORIES

- 3 Year parts/labor standard, additional 2 year warranty available
- Stainless steel or black exterior option
- Stainless steel or black interior option
- Shelves black or white
- Stainless steel clips
- Flow track
- Gravity-Flo track
- Price tag molding
- 3" or 6" Casters
- 6" Legs or seismic/flanged legs
- Door locks (swing doors only)
- Custom signage & decals
- Remote option\* (see note on back page)

### REFRIGERATION SYSTEM

- Uses environmentally friendly, energy efficient R290 refrigerant, and meets all regulatory requirements for CARB, SNAP, DOE & more
- Refrigerator has non-electric defrost with hot gas condensate evaporation
- Freezer has electric defrost with hot gas condensate evaporation
- Epoxy coated evaporator coil
- Freezer maintains product temperature to -10°F
- Refrigerator maintains product temperatures between 36°F to 38°F



  
Please verify qualifying units by visiting:  
[www.energystar.gov/cfs](http://www.energystar.gov/cfs)

3779 Champion Blvd., Winston-Salem, NC 27105  
1-888-845-9800 Fax: 1-336-245-6453  
Beverage-Air.com Sales@bevair.com



# BEVERAGE-AIR

MODEL	MMRF72HC-1-C-WW
<b>EXTERNAL DIMENSIONAL DATA</b>	
Width Overall	75"
Depth Overall (with handle)	33 1/2"
Height Overall	78 1/8"
Number of Doors	3
Depth with Door Open 90°	55 1/8"
Door Openings (in)	21 7/8" x 52 3/4"
<b>INTERNAL DIMENSIONAL DATA</b>	
NET Capacity Refrigerator (cubic ft.)	(F) 44.85 (R) 19.62
Internal Width Overall (in)	(R) 47" (F) 22"
Internal Depth Overall (in)	28 1/2"
Internal Height Top Usable (in)	55"
Number of Shelves	15
<b>ELECTRICAL DATA</b>	
Full Load Amperes Refrigerator	(R) 3.9 (F) 6.34
<b>REFRIGERATION DATA</b>	
Horsepower	(R) 1/3 (F) 3/4
Capacity (BTU/Hr)	(R) 2291 (F) 2097
Heat Rejection (BTU/Hr)	6582
Charge (lbs/grams/ounces)	(R) .2425 / 110 / 3.88 (F) .2094 / 95 / 3.35
<b>SHIPPING DATA</b>	
Gross Weight - Crated	842 lbs
Height - Crated	85"
Width - Crated	77"
Depth - Crated	36"

\*NOTE: Remote units are field wired and come with 6" legs.  
Refrigerant must be specified at time of order.

## Dual-Temp Glass Door Merchandisers

Model: MMRF72HC-1-C-WW

### Model Views

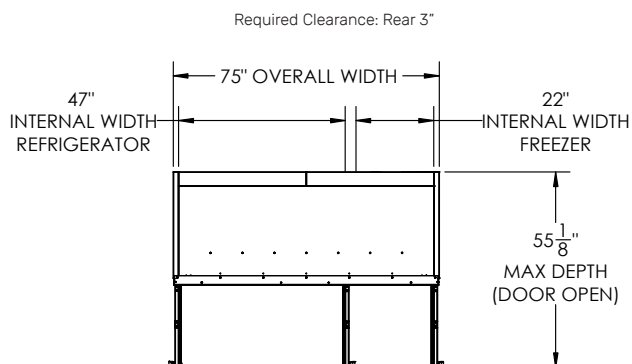

### PLAN VIEW

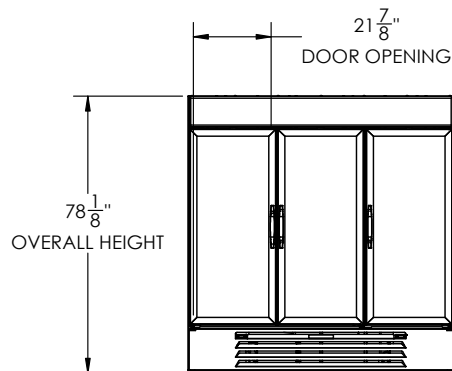

### ELEVATION VIEW

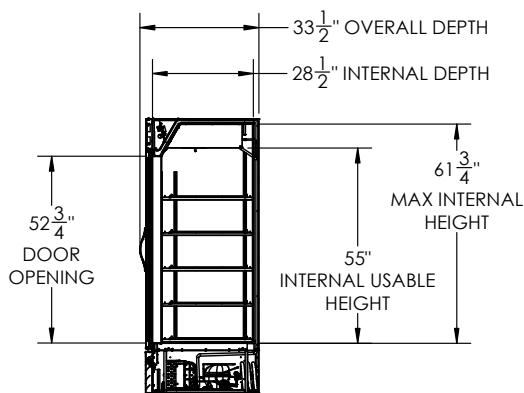

### SIDE VIEW

### ELECTRICAL CONNECTION



115/60/1  
(2) NEMA 5-15P

Unit pre-wired at factory and include 8' long cord and plug set.



3779 Champion Blvd., Winston-Salem, NC 27105 1-888-845-9800 Fax: 1-336-245-6453 Beverage-Air.com Sales@bevair.com

an Ali Group Company



The Spirit of Excellence