



BEVERAGE-AIR

Project: _____	AIA#
Item: _____	
Location: _____	SIS#
Approved: _____	

MMRF72HC GLASS DOOR MERCHANDISER SERIES - DUAL-TEMP

MARKETMAX DUAL TEMPERATURE REFRIGERATOR/FREEZER MODEL: MMRF72HC-1-B-BW
 MMRF72HC Black Hinged Triple Glass Door
 Hydrocarbon Series

5 Year Parts/Labor Warranty Available
7 Year Compressor Warranty



CABINET CONSTRUCTION

- Exterior features durable black painted steel
- Heavy duty interior construction includes white coated steel walls
- Brightly lit sign panel
- LED lighting
- Modern one-piece grille
- Full electronic control with digital display
- Dual-temp refrigerator/freezer units provide two different operating temperature zones for different types of products
- Self-contained bottom mount refrigeration system
- Left: refrigerator single section has double pane lowE glass door
- Right: freezer double section has triple pane lowE glass doors
- Self-closing doors with 120° stay-open feature
- Snap-in gaskets, easy to remove for cleaning or replacement
- Fifteen (15) heavy-duty epoxy coated wire shelves
- Four (4) shelf clips included per shelf
- Leveling feet standard

OPTIONS & ACCESSORIES

- 3 Year parts/labor standard, additional 2 year warranty available
- White or stainless steel exterior
- Black or stainless steel interior
- Shelves black or white
- Stainless steel clips
- Flow track
- Gravity-Flo track
- Price tag molding
- 3" or 6" Casters
- 6" Legs or seismic/flanged legs
- Door locks (swing doors only)
- Custom signage & decals
- Remote option* (see note on back page)

REFRIGERATION SYSTEM

- Uses environmentally friendly, energy efficient R290 refrigerant, and meets all regulatory requirements for CARB, SNAP, DOE & more
- Adaptive defrost
- Epoxy coated evaporator coil
- Freezer maintains product temperature to -10°F
- Refrigerator maintains product temperatures between 36°F to 38°F



 Please verify qualifying units by visiting:
www.energystar.gov/cfs

3779 Champion Blvd., Winston-Salem, NC 27105
 1-888-845-9800 Fax: 1-336-245-6453
 Beverage-Air.com Sales@bevair.com



BEVERAGE-AIR

Dual-Temp Glass Door Merchandisers

Model: MMRF72HC-1-B-BW

MODEL	MMRF72HC-1-B-BW
EXTERNAL DIMENSIONAL DATA	
Width Overall	75"
Depth Overall (with handle)	33 1/2"
Height Overall	78 1/8"
Number of Doors	3
Depth with Door Open 90°	55 1/2"
Door Openings (in)	21 7/8" x 52 3/4"
INTERNAL DIMENSIONAL DATA	
NET Capacity (cubic ft.)	(R) 19.62 (F) 44.85
Internal Width Overall (in)	(R) 22" (F) 47"
Internal Depth Overall (in)	28 1/2"
Internal Height Usable (in)	55"
Number of Shelves	15
ELECTRICAL DATA	
Full Load Amperes	(R) 2.88 (F) 10.0
REFRIGERATION DATA	
Horsepower	(R) 1/4 (F) 3/4
Capacity (BTU/Hr)	(R) 1702 (F) 2772
Heat Rejection (BTU/Hr)	6711
Charge (lbs/grams/ounces)	(R) .1985 / 90 / 3.18 (F) .2094 / 95 / 3.35
SHIPPING DATA	
Gross Weight - Crated	842 lbs
Height - Crated	85"
Width - Crated	77"
Depth - Crated	36"

*NOTE: Remote units are field wired and come with 6" legs.
Refrigerant must be specified at time of order.

Model Views

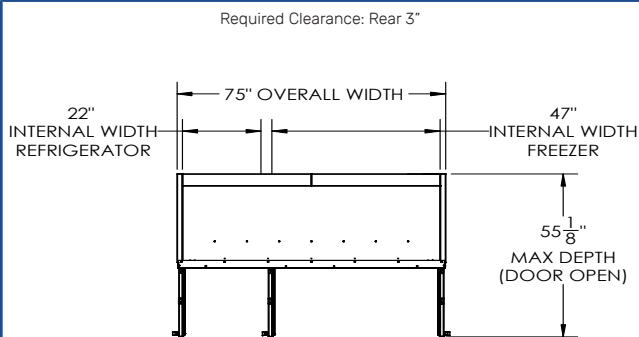

PLAN VIEW

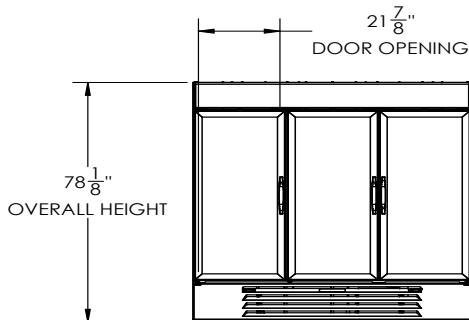

ELEVATION VIEW

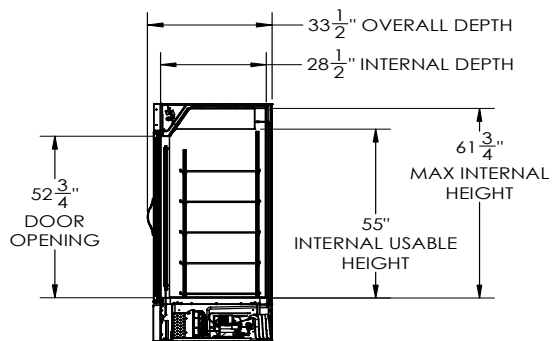

SIDE VIEW

ELECTRICAL CONNECTION



115/60/1
(2) NEMA 5-15P

Unit pre-wired at factory and include 8' long cord and plug set.

