

# iT1900 Ice Cube Machine

## Models

- IRT1900A     IDT-1900A     IYT1900A     IDT1900W  
 IYT1900W     IRT1900N     IDT1900N     IYT1900N



Indigo NXT Series iT1900 Ice Machine on D970 Bin

Designed for operators who know that ice is critical to their business, the Indigo NXT Series ice machine's preventative diagnostics continually monitor itself for reliable ice production. Improvements in cleanability and programmability make your ice machine easy to own and less expensive to operate.

- **New levels of Performance** – Showcasing an average of 14% lower energy consumption, 10% reduction in potable water usage and a 23% reduction in condenser water usage. This translates into lower cost of ownership over the life of your machine.
- **easyTouch® Display** - New icon based touch screen takes the guess work out of owning and operating an ice machine.
- **Programmable Ice Production** – Now its super easy to program your ice machine to be off at certain times of the day to save money with fluctuating electrical rates. Also programmable by daily ice production volume.
- **Easy to Clean Foodzone** – Easy Access front door panel. Removable water-trough, distribution tube, curtain, and sensing probes for fast and efficient cleaning. Select components made with AlphaSan® antimicrobial.
- **Intelligent Diagnostics** – Provides 24 hour preventative maintenance and diagnostic feedback for trouble free operation.
- **Acoustical Ice Sensing Probe** – Unique patented technology allows for reliable operation in challenging water conditions and environments
- **DuraTech® Exterior** – Provides superior corrosion resistant above stainless steel. Innovative clear-coat resists fingerprints and dirt making it easier to keep clean.
- Available **LuminIce® II Growth Inhibitor** – Controls the growth of bacteria and yeast within the Food zone keeping the machine cleaner longer. A new indicator in the display keeps you abreast of the operational status.

## Ice Machine Electric

208-230/60/1 standard

### Minimum circuit ampacity:

Air-cooled:	20.1 1ph	14.4 3ph
Water-cooled:	18.8 1ph	13.0 3ph
Remote-cooled:	19.3 1ph	13.1 3ph

### Maximum fuse size:

Air-cooled:	30 1ph	20 3ph
Water-cooled:	30 1ph	20 3ph
Remote-cooled:	30 1ph	20 3ph



## Specifications

### Operating Limits:

**BTU Per Hour:**  
26,100 (average),  
and 30,500 (peak)

- Ambient Temperature Range: 40° to 110°F (4.4° to 43.3° C)
- Water Temperature Range: 40° to 90°F (4.4° to 32.2° C)

**Refrigerant:**  
R-410 CFC-free

- Water Pressure Ice Maker Water In:  
Min. 20 psi (137.9 kPa)  
Max. 80 psi (551.1 kPa)

## Ice Shape

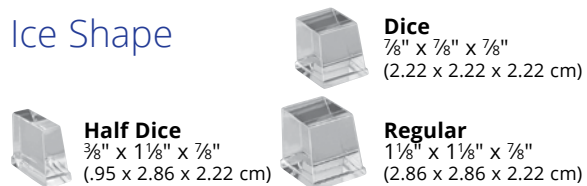

COMPANY WITH QUALITY SYSTEM



**iT1900 on D970 Storage Bin**

- Ⓐ Electrical Entrance (2) Options
- Ⓑ 1/2" (1.27 cm) F.P.T. Water Condenser Outlet (water-cooled units)
- Ⓒ 3/8" (0.95 cm) F.P.T. Water Condenser Inlet (water-cooled units)
- Ⓓ 3/8" (0.95 cm) F.P.T. Ice Making Water Inlet
- Ⓔ 1/2" (1.27 cm) F.P.T. Ice Making Water Drain
- Ⓕ 1/2" (1.27 cm) Auxillary Base Drain Socket
- Ⓖ 3/4" (1.91 cm) Bin Drain

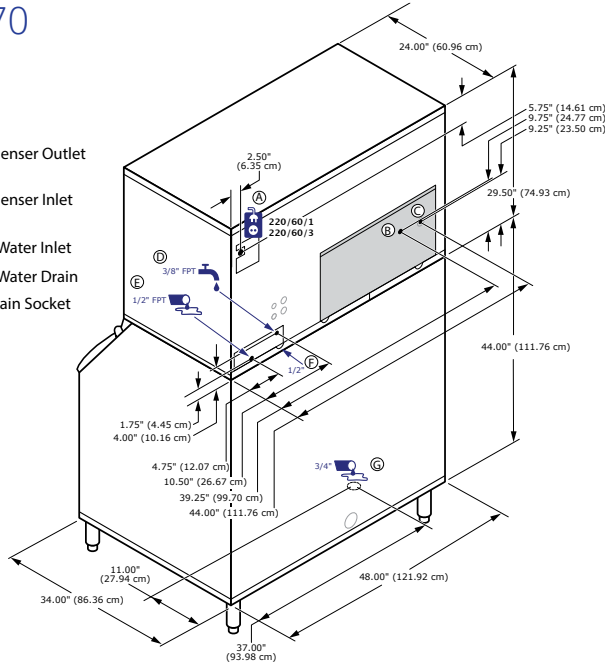

**Installation Note**

*Air Cooled clearance:*

- Top: 12" (30.5 cm)
- Sides: 8" (20.3 cm)
- Back: 5" (12.5 cm)

*Water Cooled clearance:*

- Top/Sides: 8" (20.3 cm)
- Back: 5" (12.7 cm)

**Space-Saving Design**



	<b>iT1900 D970</b>
<b>Height</b>	79.50" 201.90 cm
<b>Width</b>	48.00" 121.92 cm
<b>Depth</b>	34.00" 86.30 cm
<b>Bin Storage</b>	710lbs 322.2 kgs

*Height includes adjustable bin legs 6.00" to 8.00", (15.24 to 20.32 cm) set at 6.00" (15.24 cm).*

**Specifications**

	Model	Ice Shape	Ice Production 24 Hours		Power Usage kWh/100 lbs. @90°Air/70°F	Potable Water Usage/100 lbs. 45.4 kgs. of Ice
			70°Air/ 50°F Water	90°Air/ 70°F Water		
<b>AIR-COOLED</b>	IRT1900A	regular	1,895 lbs.	1,407 lbs.	4.65	20 Gal.
			860 kgs	638 kgs		75.7 L
	IDT1900A	dice	1,965 lbs.	1,470 lbs.	4.62	20 Gal.
<b>WATER-COOLED</b>	IYT1900A	half-dice	1,965 lbs.	1,535 lbs.	4.60	20 Gal.
			891 kgs	696 kgs		75.7 L
	IDT1900W	dice	1,900 lbs.	1,666 lbs.	3.51	20 Gal.
<b>REMOTE-COOLED</b>	IYT1900W	half-dice	1,960 lbs.	1,758 lbs.	3.44	20 Gal.
			889 kgs	797 kgs		75.7 L
	* Water-cooled Condenser Water Usage / 100 lbs. /45.4 kgs. Of Ice: 145 gal./ 549 L. * Water-cooled models are excluded from ENERGY STAR qualification.					
<b>REMOTE-COOLED</b>	IRT1900N	regular	1,780 lbs.	1,545 lbs.	4.26	20 Gal.
			807 kgs	701 kgs		75.7 L
	IDT1900N	dice	1,915 lbs.	1,643 lbs.	4.02 ★	20 Gal.
<b>REMOTE-COOLED</b>	IYT1900N	half-dice	2,020 lbs.	1,744 lbs.	4.00 ★	20 Gal.
			916 kgs.	791 kgs		75.7 L

*Order separately: Ice storage bin for all units, line-set and remote condenser unit JCT1500 for remote cooled units.*

**Accessories**

**LuminIce<sup>®</sup> II Growth Inhibitor**  
reduces yeast and bacteria growth for a cleaner ice machine.



**External Scoop holder**  
Protect the ice scoop with the NSF approved versatile scoop holder.



**Arctic Pure<sup>®</sup> Water Filters**  
Reduces sediment and chlorine odors for better tasting ice.



**iAUCS<sup>®</sup>**  
schedules and performs routine ice machine cleaning automatically.

