

# iF0900N Ice Cube Machine

iF0900N Ice Cube Machine

Model:

- IDF-0900N  
 IYF-0900N



Indigo NXT Series iF0900N Ice Machine on a D570 Bin

Designed for operators who know that ice is critical to their business, the Indigo<sup>®</sup>NXT Series ice machine's preventative diagnostics continually monitor itself for reliable ice production. Improvements in cleanability and programmability make your ice machine easy to own and less expensive to operate.

- **easyTouch<sup>®</sup> Display**- New icon based touch screen takes the guess work out of owning and operating an ice machine.
- **Programmable Ice Production** – Now its super easy to program your ice machine to be off at certain times of the day to save money with fluctuating electrical rates. Also programmable by daily ice production volume.
- **Easy to Clean Foodzone** – Hinged front door swings out for easy access. Removable water-trough, distribution tube, curtain, and sensing probes for fast and efficient cleaning. Select components made with AlphaSan<sup>®</sup> antimicrobial.
- **Intelligent Diagnostics** – provide 24 hour preventative maintenance and diagnostic feedback for trouble free operation.
- **Acoustical Ice Sensing Probe** – Unique patented technology allows for reliable operation in challenging water conditions and environments.
- **DuraTech<sup>™</sup> Exterior** – provides superior corrosion resistant above stainless steel. Innovative clear-coat resists fingerprints and dirt making it easier to keep clean.
- **Available LuminIce II Growth Inhibitor**- Controls the growth of bacteria and yeast with the food zone keep the machine cleaner longer. A new indicator in the display keeps you abreast of the operational status.

## Specifications

### BTU Per Hour:

12,700 (average)  
14,800 (peak)

### Refrigerant:

R-404A CFC-free

### Operating Limits:

Ambient Temperature Range:  
40 to 110 F (4.4 to XX.XX)

Remote Condenser:  
-20 to 120 F (-29 to 49C)

Water Temperature Range:  
40 to 90 F (4.4 to 32.2 C )

Water Pressure Ice Maker Water In:  
Min. 20 psi (137.9 kPA)  
Max. 80 psi (551.1 kPA)

## Ice Machine Electric

208-230/60/1  
(208-230/60/3 and 230/50/1 also available)

### Minimum circuit ampacity:

Remote: 9.8 1ph 7.2 3ph

### Maximum fuse size:

Remote: 20 1ph 15 3ph



## Ice Shape

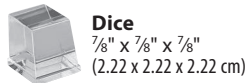
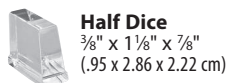

COMPANY WITH QUALITY SYSTEM



### iF0900N on D-570 Storage Bin

- (A) Electrical Entrance (2) Options
- (B) 3/8" (0.95 cm) F.P.T. Water Condenser Inlet (water-cooled units)
- (C) 1/2" (1.27 cm) F.P.T. Water Condenser Outlet (water-cooled units)
- (D) 1/2" (1.27 cm) Auxillary Base Drain Socket
- (E) 3/8" (0.95 cm) F.P.T. Ice Making Water Inlet
- (F) 1/2" (1.27 cm) F.P.T. Ice Making Water Drain
- (G) 3/4" (1.91 cm) Bin Drain

**Installation Note**  
Minimum installation clearance:

Top/sides: 8" (20.32 cm); Back is 5" (12.7 cm)

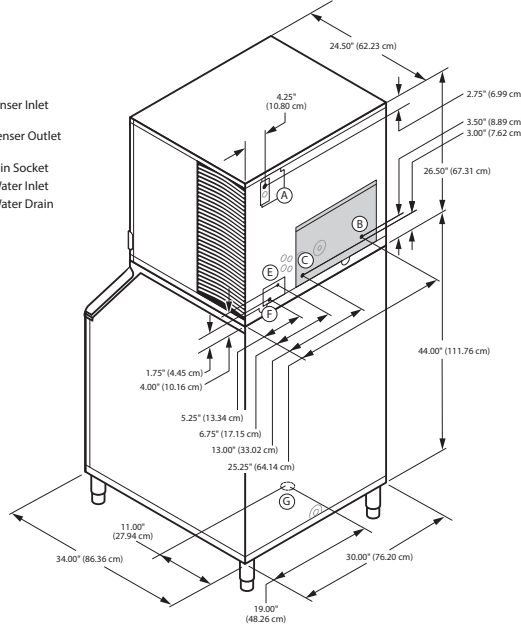

### Space-Saving Designs



|             | iF0900N D-570         | iF0900N D-970         |
|-------------|-----------------------|-----------------------|
| Height      | 76.50"<br>194.30 cm   | 76.50"<br>194.30 cm   |
| Width       | 30.00"<br>76.20 cm    | 30.00"<br>76.20 cm    |
| Depth       | 34.00"<br>86.30 cm    | 34.00"<br>86.30 cm    |
| Bin Storage | 365 lbs.<br>165.7 kgs | 543 lbs.<br>241.1 kgs |

Height includes adjustable bin legs 6.00" to 8.00", (15.24 to 20.32 cm) set at 6.00" (15.24 cm).  
Bin capacity is based on 90% of the volume x 33 lbs/ft<sup>3</sup> average density of ice

### Specifications

| Model     | Ice Shape | Ice Production 24 Hours |        |                    |        | Power Usage kWh/100 lbs.@90°Air/70°F |      | Water Usage/100 lbs. 45.4 kgs. of Ice |        |
|-----------|-----------|-------------------------|--------|--------------------|--------|--------------------------------------|------|---------------------------------------|--------|
|           |           | 70°Air/ 50°F Water      |        | 90°Air/ 70°F Water |        | 1 Ph                                 | 3 Ph | Potable Water                         |        |
|           |           | 793 lbs                 | 360 kg | 710 lbs            | 322 kg | 5.20                                 | 5.20 | 19 Gal.                               | 71.9 L |
| IDF-0900N | dice      |                         |        |                    |        |                                      |      |                                       |        |
| IYF-0900N | half-dice | 830 lbs                 | 376 kg | 740 lbs            | 336 kg | 5.0                                  | 5.0  | 19 Gal.                               | 71.9 L |

### Standard Remote Tubing Kits

| Tubing Kit | Tubing Length  |
|------------|----------------|
| RT20R404   | 20 ft / 6.1 m  |
| RT35R404   | 35 ft / 10.7 m |
| RT50R404   | 50 ft / 15.2   |



Standard air-cooled remote JCF0900-161

Ice storage bin and JCF0900 remote condenser must be ordered separately. Consult remote condenser specification sheet for details.  
Tubing Kits come pre-charge with quick connects. When ordering, add an A suffix at the end of the electrical option. Example: IYF0900N-261A

### Accessories

**LuminIce® II Growth Inhibitor**  
reduces yeast and bacteria growth for a cleaner ice machine.



#### External Scoop holder

Protect the ice scoop with the NSF approved versatile scoop holder.

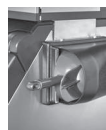

#### Arctic Pure® Water Filters

Reduces sediment and chlorine odors for better tasting ice.



**iAuCS®** schedules and performs routine ice machine cleaning automatically.

