



# BEVERAGE-AIR

Project: _____	AIA#
Item: _____	
Location: _____	SIS#
Approved: _____	

# HFP3HC TOP MOUNT REACH-IN FREEZER

## HORIZON TOP MOUNT REACH-IN HFP3HC Half-Solid Triple Door Reach-In Freezer Hydrocarbon Series

**MODEL:**  
**HFP3HC-1HS**



**5 Year Parts/Labor Warranty Available**  
**7 Year Compressor Warranty**

### CABINET CONSTRUCTION

- Exterior is stainless steel front and sides
- Interior liner is made of corrosion resistant aluminum
- Full electronic control
- Expansion valve technology
- One piece grille
- LED interior light
- Self-closing door with 120° stay-open feature, on cam-lift hinges
- Field reversible doors
- Door locks
- Snap-in magnetic gaskets for positive door seal
- Nine (9) heavy-duty epoxy coated wire shelves
- 6" Heavy-duty casters, two (2) with brakes
- 8' Cord and plug (see electrical data for details)

### OPTIONS & ACCESSORIES

- 3 Year parts/labor standard, additional 2 year warranty available
- Tray slide pair, 1 tray slide set for (1) 18" x 26" or (2) 14" x 18" pans (A)
- Stainless steel universal tray slide pair, 1 tray slide set for (1) 18" x 26" or (2) 14" x 18" pans (AC)
- Tray slide kit #4 (19 sets per half section)
- Additional epoxy shelves
- Shelf clips
- Stainless steel breaker
- 6" Legs seismic/flanged
- 3" Casters
- Remote option\* (see note on back page)

### REFRIGERATION SYSTEM

- Uses environmentally friendly, energy efficient R290 refrigerant, and meets all regulatory requirements for CARB, SNAP, DOE & more
- Hot gas condensate evaporator
- Adaptive defrost
- Epoxy coated evaporator coil
- Freezer capable of maintaining product temperature down to -10°F



 Please verify qualifying units by visiting:  
[www.energystar.gov/cfs](http://www.energystar.gov/cfs)

3779 Champion Blvd., Winston-Salem, NC 27105  
1-888-845-9800 Fax: 1-336-245-6453  
Beverage-Air.com Sales@bevair.com



# BEVERAGE-AIR

MODEL	HFP3HC-1HS
<b>EXTERNAL DIMENSIONAL DATA</b>	
Width Overall	78"
Depth Overall with Handle	33 5/8"
Height Overall	85"
Number of Doors	6
Depth with Door Open 90°	55 1/8"
Door Openings (in)	21 5/8" x 29 5/8"
<b>INTERNAL DIMENSIONAL DATA</b>	
NET Capacity (cubic ft.)	69.1
Internal Width Overall (in)	74"
Internal Depth Overall (in)	25 7/8"
Internal Height Overall (in)	62"
Number. of Shelves	9
<b>ELECTRICAL DATA</b>	
Full Load Amperes 115/60/1	13.2
<b>REFRIGERATION DATA</b>	
Horsepower	(2) 3/4
Capacity (BTU/Hr)	3854
Heat Rejection (BTU/Hr)	5781
Charge (lbs/grams)	0.2866/130
<b>SHIPPING DATA</b>	
Gross Weight - Crated	744 lbs
Height - Crated	88"
Width - Crated	81"
Depth - Crated	36"

\*NOTE: Remote units are field wired and come with 6" legs.  
Refrigerant must be specified at time of order.

## Top Mount Reach-In Freezer Model: HFP3HC-1HS

### Model Views

Required Clearance: Top 12", Rear 3", Sides 0"

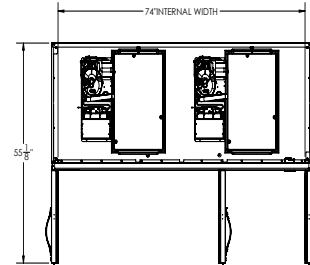

### PLAN VIEW

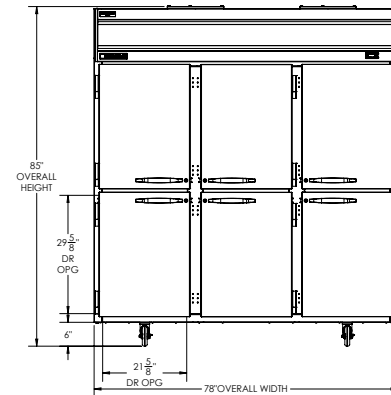

### ELEVATION VIEW

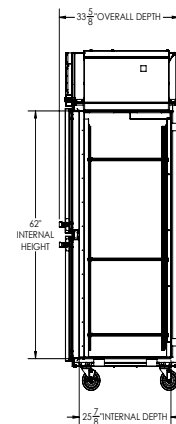

### SIDE VIEW

### ELECTRICAL CONNECTION



115/60/1  
NEMA 5-15P

Unit pre-wired at factory and include 8' long cord and plug set.



3779 Champion Blvd., Winston-Salem, NC 27105 1-888-845-9800 Fax: 1-336-245-6453 Beverage-Air.com Sales@bevoir.com

an Ali Group Company



The Spirit of Excellence