



BEVERAGE-AIR

Project: _____	AIA#
Item: _____	
Location: _____	SIS#
Approved: _____	

HBF19HC BOTTOM MOUNT REACH-IN FREEZER

HORIZON BOTTOM MOUNT REACH-IN

HBF19HC Solid Door Reach-In Freezer

Hydrocarbon Series

MODEL:
HBF19HC-1



5 Year Parts/Labor Warranty Available
7 Year Compressor Warranty

CABINET CONSTRUCTION

- Stainless steel front, side, and grille (galvanized back & bottom)
- Stainless steel interior
- LED lighting
- Full electronic control with one-touch defrost
- Expansion valve technology
- One-piece grille allow easy removal/installation for preventative maintenance
- Door lock (solid doors only)
- Self closing door with 120° stay open feature
- Spring-loaded style hinges
- Plug-in magnetic door gaskets
- Three (3) heavy duty epoxy coated wire shelves
- 6" Casters with two (2) brakes

OPTIONS & ACCESSORIES

- 3 Year parts/labor standard, additional 2 year warranty available
- 3" Casters or 6" legs
- Epoxy shelves
- Shelf clips
- Remote option* (see note on back page)

REFRIGERATION SYSTEM

- Uses environmentally friendly, energy efficient R290 refrigerant, and meets all regulatory requirements for CARB, SNAP, DOE & more
- Hot gas condensate evaporator
- Adaptive defrost
- Epoxy coated evaporator coil
- Freezer capable of maintaining product temperature down to -10°F



 ENERGY STAR
Please verify qualifying units by visiting:
www.energystar.gov/cfs

3779 Champion Blvd., Winston-Salem, NC 27105
1-888-845-9800 Fax: 1-336-245-6453
Beverage-Air.com Sales@bevair.com



BEVERAGE-AIR

MODEL	HBF19HC-1
EXTERNAL DIMENSIONAL DATA	
Width Overall	27 ¼"
Depth Overall with Handle	27 ¾"
Height Overall with Casters	84 ⅞"
Number of Doors	1
Depth with Door Open 90°	51 ½"
Door Opening (in)	24 ⅞" x 52 ½"
INTERNAL DIMENSIONAL DATA	
NET Capacity (cubic ft.)	19.08
Internal Width Overall (in)	24 ¼"
Internal Depth Overall (in)	22 ½"
Internal Height Overall (in)	61 ¾"
Internal Height Useable (in)	55"
Number of Shelves	3
ELECTRICAL DATA	
Full Load Amperes 115/60/1	6.34
REFRIGERATION DATA	
Horsepower	¾
Capacity (BTU/Hr)	2097
Heat Rejection (BTU/Hr)	3145
Charge (lbs/grams/ounce)	0.2094 / 95 / 3.35
SHIPPING DATA	
Gross Weight - Crated	364 lbs
Height - Crated	88"
Width - Crated	30"
Depth - Crated	36"

*NOTE: Remote units are field wired and come with 6" legs.
Refrigerant must be specified at time of order.

Bottom Mount Reach-In Freezer Model: HBF19HC-1

Model Views

Required Clearance: Bottom & Rear 3"

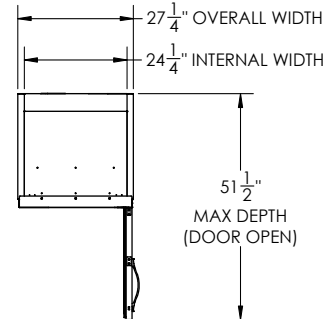

PLAN VIEW

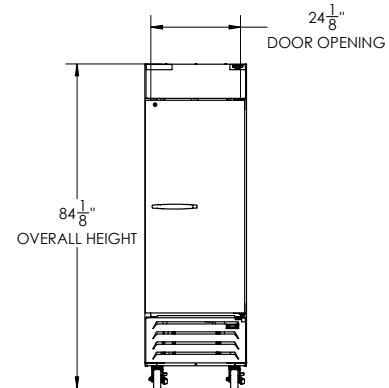

ELEVATION VIEW

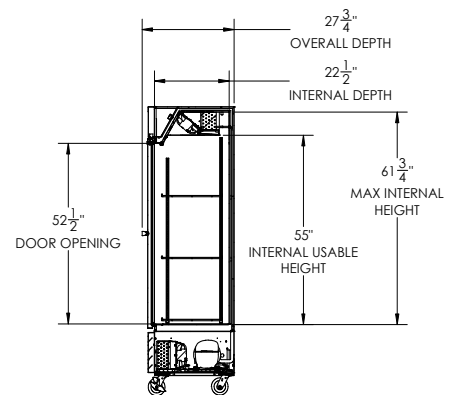

SIDE VIEW

ELECTRICAL CONNECTION



115/60/1
NEMA 5-15P

Unit pre-wired at factory
and include 8' long cord
and plug set.

