



# BEVERAGE-AIR

Project: _____	AIA#
Item: _____	
Location: _____	SIS#
Approved: _____	

**GF24HC BAR EQUIPMENT: GLASS AND PLATE FROSTER SERIES**

## GF BAR EQUIPMENT

### GF24HC Glass and Plate Froster Hydrocarbon Series

**MODEL:**  
GF24HC-B



**5 Year Parts/Labor Warranty Available**  
**7 Year Compressor Warranty**

#### CABINET CONSTRUCTION

- Exterior features durable black painted steel
- Interior construction utilizes galvanized steel
- Top includes easy glide, stainless steel lids (1) and stainless steel counter top with edge
- Top loading
- Two (2) adjustable wire dividers
- Two (2) shelf ledges with three (3) mounting points
- Flexibility in design provides for plate storage and chilling
- Automatic defrost of coil is standard
- Built-in condensate evaporator system
- No floor drain or additional plumbing is needed

#### OPTIONS & ACCESSORIES

- 3 Year parts/labor standard, additional 2 year warranty available
- Stainless steel interior
- Lock
- Remote option\*  
(refrigerant must be specified at time of order, see note on back on page)

#### REFRIGERATION SYSTEM

- Uses environmentally friendly, energy efficient R290 refrigerant, and meets all regulatory requirements for CARB, SNAP, DOE & more
- Adaptive defrost
- Epoxy coated evaporator coil
- Chills glasses and plates at 0°F and below (factory setpoint is 0°F)



  
Please verify qualifying units by visiting:  
[www.energystar.gov/cfs](http://www.energystar.gov/cfs)

3779 Champion Blvd., Winston-Salem, NC 27105  
1-888-845-9800 Fax: 1-336-245-6453  
Beverage-Air.com Sales@bevair.com



# BEVERAGE-AIR

## Bar Equipment - Glass and Plate Froster Model: GF24HC-B

MODEL	GF24HC-B
<b>EXTERNAL DIMENSIONAL DATA</b>	
Width Overall	24"
Depth Overall	26 1/8"
Height Overall	33 5/8"
Number of Lids	1
<b>INTERNAL DIMENSIONAL DATA</b>	
NET Capacity (cubic ft.)	4.0
Internal Width Overall (in)	19 7/8"
Internal Max Depth Overall (in)	22"
Internal Height Overall (in)	18 1/4"
Number of Dividers	2
12 oz. Mugs Chilling Capacity	76
8" Plate Chilling Capacity	100
<b>ELECTRICAL DATA</b>	
Full Load Amperes	3.5
<b>REFRIGERATION DATA</b>	
Horsepower	1/2
Capacity (BTU/Hr)	1624
Heat Rejection (BTU/Hr)	2436
Charge (lbs/grams)	0.1323/60
<b>SHIPPING DATA</b>	
Gross Weight - Crated	186 lbs
Height - Crated	38"
Width - Crated	27"
Depth - Crated	30"

\*NOTE: Remote units are field wired and come with 6" legs.  
Refrigerant must be specified at time of order.

### Model Views

Required Clearance: 2" Rear

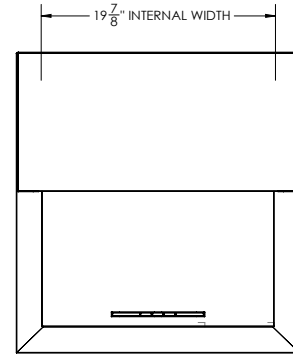

PLAN VIEW

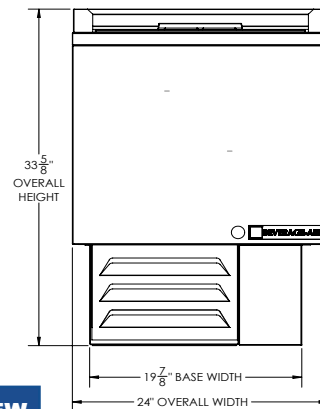

ELEVATION VIEW

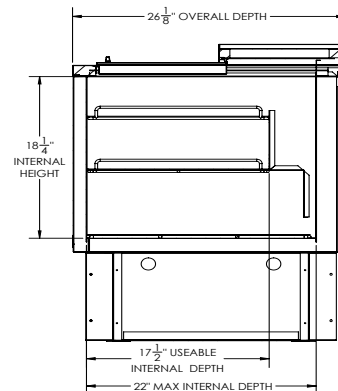

SIDE VIEW



### ELECTRICAL CONNECTION



115/60/1  
NEMA 5-15P

Unit pre-wired at factory  
and include 8' long cord  
and plug set.