

# OPEN AIR MERCHANDISERS HORIZONTAL · 35" DEEP · SHORT



## EOMH-48-W-35-S

## EOMH Series



### Refrigeration System

- Bottom mounted, self-contained and fully detachable Blizzard R290 condensing unit uses environmentally friendly, EPA-compliant R290 refrigerant with zero (0) Ozone Depletion Potential (ODP) and three (3) Global Warming Potential (GWP). Blizzard R290 is easily replaceable and requires no on-site brazing.
- Front air intake and rear air discharge design allows side by side installation.
- Electronically commutated (ECM) evaporator fan motors achieve rapid cooling with less energy consumption.
- High performance, auto-reverse condenser fan motor supports compressor ventilation and condenser coil cleaning.
- Large capacity, corrosion-resistant condenser and evaporator coils.
- Self-maintaining, energy-efficient condensate drain pan requires no external drains or electric heaters.
- Pre-wired and ready to plug, 115V/60Hz/1Ph, NEMA 5-20P. 230V/60Hz/1Ph, NEMA 6-20P (see table for plug types).

### Cabinet Construction

- White modern exterior has moisture-resistant panels and field replaceable tempered glass.
- Heavy-duty stainless steel interior has perforated back wall for efficient air flow. Includes floor drains for ease of cleaning.
- Front stainless steel bumper belt protects against shopping cart impact.
- Galvanized steel top, bottom and rear.
- 2.5" thick high-density polyurethane insulation.
- Integrated retractable night curtain saves energy and provides security.
- 5" swivel casters with locks on front set. Leg stabilizers included.

### Lighting

- Shielded LED bar lighting under shelves and canopy provide bright, high color illumination at lower heat output. On/off switch saves energy.

### Shelving

- Removable 2-tier stainless steel shelf riser.

### Temperature Control

- Factory preset temperature of 35°F maintains a combined average product temperature of 40°F or less.
- Audible overheat protection alarm for compressor and condenser coil.

### Recommended Operating Conditions

- Conforms to NSF standard 7 TYPE II designed to operate in an air-conditioned environment where temperature and humidity do not exceed 80°F and 55% respectively.
- Must not be installed near ventilation systems, fans or exterior doors or windows that will disrupt the air curtain.
- Must not be installed in direct sunlight.
- In built-in applications, a distance of 6" is required on the front, back and top exterior for ventilation purposes



Type	Capacity Cu. Ft.	Shelves	NEMA Plug	Refrigerant	HP	Power V-Hz-Ph	Amps	Crated Weight	Exterior Dimensions		
									L	D	H*
REF	7.3	-	NEMA 5-20P	R-290	3/4	115-60-1	7.5	531 lbs	48"	34.25"	41"

(†)Based on evaporating temperature of 23°F (-5°C) & condensing temperature of 131°F (55°C). (P) Product capacity is calculated based on standard industry figures. (\*) Reference plan view for clarification on caster/unit height. If dimensions and capacity are critical, please contact Everest Refrigeration. Blizzard R290 replacement is at the sole discretion of Everest Refrigeration. Specifications subject to change without notice.

# OPEN AIR MERCHANDISERS

## HORIZONTAL · 35" DEEP · SHORT



### EOMH-48-W-35-S

### EOMH Series

#### DIMENSIONAL DATA

External Dims.	L	48 in.
	D	34.25 in.
	H*	41 in.
Crated Weight	531 lbs.	
Doors/Drawers/Lids	-	
Max Weight Support	-	

#### STORAGE DATA

Net Capacity Cu. Ft. †	7.3
Shelves	-
Barrels	-
20 oz. Bottles	-
12 oz. Bottles	-
12 oz. Cans	-
8" Mugs	-
# of Pans (Top)	-
# of Pans (Drawer)	-
Dividers	-
Trays	-

#### ELECTRICAL DATA

Voltage	115-60-1
Full Load Amperage	7.5A
Feed Wires w/ Ground	3
Cord Length	9ft
NEMA Plug Type	Ⓜ NEMA 5-20P

#### REFRIGERATION DATA

Compressor	Bottom
Refrigerant	R-290
Compressor HP	3/4
BTU/HR †	-

#### KEY

<b>D</b>	Door	<b>R</b>	Refrigerator
<b>L</b>	Lid	<b>REF</b>	Refrigerator
<b>H</b>	Half Door	<b>F</b>	Freezer
<b>FD</b>	Full Door	<b>FRZ</b>	Freezer
<b>SD</b>	Solid Door	<b>DUAL</b>	REF/FRZ Combo
<b>GD</b>	Glass Door	<b>DR</b>	Drawer

	Elevation	Right	Plan	3D	Back

#### PLAN VIEW

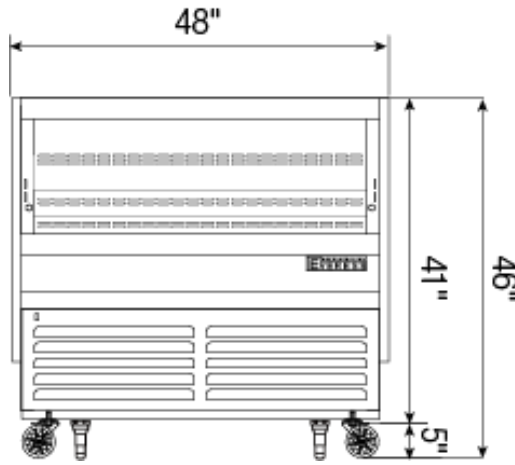

FRONT

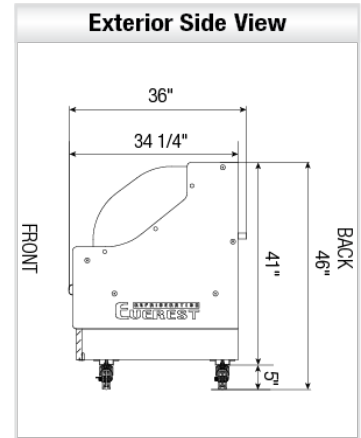

SIDE

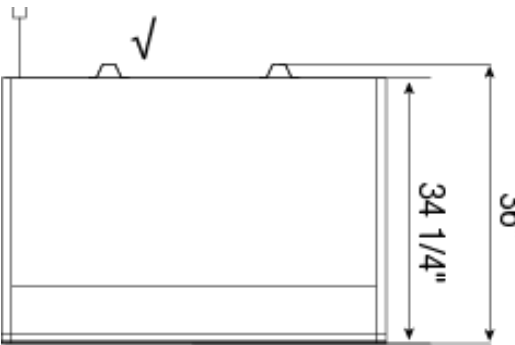

TOP

#### ACCESSORIES & OPTIONS

(†)Based on evaporating temperature of 23°F (-5°C) & condensing temperature of 131°F (55°C). (‡) Product capacity is calculated based on standard industry figures. (\*) Reference plan view for clarification on caster/unit height. If dimensions and capacity are critical, please contact Everest Refrigeration. Blizzard R290 replacement is at the sole discretion of Everest Refrigeration. Specifications subject to change without notice.