

SOLID SLIDE LID GLASS & PLATE CHILLER



EGC37

EGC Series



Refrigeration System

- Bottom mounted, self-contained and retractable condensing unit uses environmentally friendly, EPA compliant R290 refrigerant with zero (0) Ozone Depletion Potential (ODP) and three (3) Global Warming Potential (GWP). Blizzard R290 is easily replaceable and requires no on-site brazing.
- Electronically commutated (ECM) fan motors achieve rapid cooling with less energy consumption.
- Full-length air duct ensures optimal cold air circulation.
- Time-initiated and temperature-terminated defrost cycle with defrost heater.
- Large capacity, corrosion-resistant condenser and evaporator coils.
- Self-maintaining, energy-efficient condensate drain pan requires no external drains or electric heaters.
- High performance, auto-reverse condenser fan motor supports compressor ventilation and condenser coil cleaning.
- Pre-wired and ready to plug, 115V/60Hz/1Ph, NEMA 5-15P

Cabinet Construction

- Heavy duty stainless steel countertop and rails with textured laminate, black vinyl exterior.
- Open spaced interior with no walls between compartments.
- Galvanized steel interior.
- 1 3/4" thick high density polyurethane insulation.
- Built-in caster thread receptacles.

Lighting

- Shielded LED bar lighting with on/off switch provides bright, high color illumination at lower heat output.

Lids

- Heavy duty stainless steel exterior and galvanized steel interior.
- 3/4" thick high density polyurethane insulation.
- Removable ratchet locks keep your items safe from theft.

Shelving

- Two levels of epoxy coated, steel wire shelves slide horizontally for easy storage of glasses and plates (see table for quantity).

Temperature Control

- Multi-function digital controller with easy to read LED display.
- Factory preset temperature, -4°F.
- Temperature setting range from -10°F to 54°F.
- Audible overheat protection alarm for compressor and condenser coil.

Options

- 3" or 5" swivel casters with locks.
- 3.5" - 6" height-adjustable and interchangeable legs.



Type	Doors	Capacity		Shelves	Refrigerant	HP	Power V-Hz-Ph	Amps	Crated Weight	Exterior Dimensions		
		Cu. Ft.	8" Mugs							L	D	H*
FRZ	1	11	160	3	R-290	1/2	115-60-1	5	209 lbs	36.75"	26.75"	33.75"

(†)Based on evaporating temperature of 23°F (-5°C) & condensing temperature of 131°F (55°C). (‡) Product capacity is calculated based on standard industry figures. (*) Reference plan view for clarification on caster/unit height. If dimensions and capacity are critical, please contact Everest Refrigeration. Blizzard R290 replacement is at the sole discretion of Everest Refrigeration. Specifications subject to change without notice.

SOLID SLIDE LID GLASS & PLATE CHILLER



EGC37

EGC Series

DIMENSIONAL DATA

External Dims.	L	36.75 in.
	D	26.75 in.
	H*	33.75 in.
Crated Weight	209 lbs.	
Doors/Drawers/Lids	1	
Max Weight Support	-	

STORAGE DATA

Net Capacity Cu. Ft. †	11
Shelves	3
Barrels	-
20 oz. Bottles	-
12 oz. Bottles	-
12 oz. Cans	-
8" Mugs	160
# of Pans (Top)	-
# of Pans (Drawer)	-
Dividers	-
Trays	-

ELECTRICAL DATA

Voltage	115-60-1
Full Load Amperage	5A
Feed Wires w/ Ground	3
Cord Length	9ft
NEMA Plug Type	NEMA 5-15P

REFRIGERATION DATA

Compressor	Side
Refrigerant	R-290
Compressor HP	1/2
BTU/HR †	1979

KEY

D	Door	R	Refrigerator
L	Lid	REF	Refrigerator
H	Half Door	F	Freezer
FD	Full Door	FRZ	Freezer
SD	Solid Door	DUAL	REF/FRZ Combo
GD	Glass Door	DR	Drawer

	Elevation	Right	Plan	3D	Back

PLAN VIEW

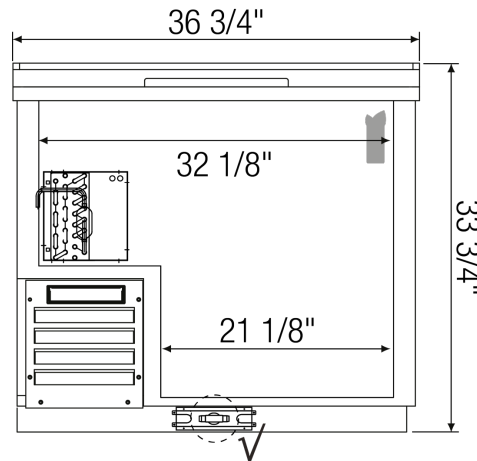

FRONT

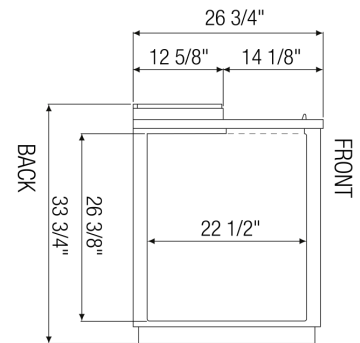

SIDE

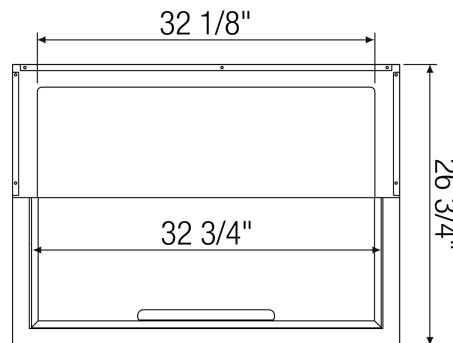

TOP

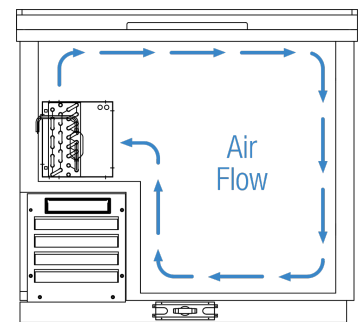

AIRFLOW

ACCESSORIES & OPTIONS

- AJL03-00 - Interchangeable Leg for Caster (Optional)
- CASA3-01 - 3" Overall Height Caster Assembly - (2) Front (2) Rear
- CASA5-01 - 5" Overall Height Caster Assembly - (2) Front (2) Rear

(†)Based on evaporating temperature of 23°F (-5°C) & condensing temperature of 131°F (55°C). (‡) Product capacity is calculated based on standard industry figures. (*) Reference plan view for clarification on caster/unit height. If dimensions and capacity are critical, please contact Everest Refrigeration. Blizzard R290 replacement is at the sole discretion of Everest Refrigeration. Specifications subject to change without notice.