



BEVERAGE-AIR

Project: _____	AIA#
Item: _____	SIS#
Location: _____	
Approved: _____	

DIPPING CABINET FREEZER

BDC-HC Dipping Cabinet 8-Flavors

Hydrocarbon Series

MODEL:
BDC-HC-8

BDC-HC DIPPING CABINET FREEZER



5 Year Parts/Labor Warranty Available
7 Year Compressor Warranty

CABINET CONSTRUCTION

- Galvanized metal cabinet with powder coated painted surface
- Interior easy to clean per-painted steel
- Adjustable thermostat
- LED lighting
- Glass lids are LowE tempered sliding glass lids with locks and keys standard
- 2" Heavy-duty casters allow easy and fast movement
- Drain plug for easy cleaning
- Lexan sneeze guard
- BDC-8 includes (4) 2- ring tub holds with space for (8) 3 gallon containers, lower level provides extra container storage of six (6) 3 gallon containers
- Cold wall refrigeration system, maintains 0° to -10°F

OPTIONS & ACCESSORIES

- 3 Year parts/labor standard, additional 2 year warranty available
- Dip Well
- Two ring tub holder
- Graphics

REFRIGERATION SYSTEM

- Refrigeration system uses R290 refrigerant to comply with all environmental concerns
- The unit is best suited for an environment where temperatures remain below 75°F and humidity does not exceed 55%
- Areas with direct sunlight should also be avoided
- Triple access air flow compressor compartment
- Maintenance free condenser



Please verify qualifying units by visiting:
www.energystar.gov/cfs

3779 Champion Blvd., Winston-Salem, NC 27105
1-888-845-9800 Fax: 1-336-245-6453
Beverage-Air.com Sales@bevair.com



BEVERAGE-AIR

MODEL	BDC-HC-8
EXTERNAL DIMENSIONAL DATA	
Width Overall	50 3/4"
Depth Overall	26 1/10"
Height Overall	52"
Tub Holders	6
INTERNAL DIMENSIONAL DATA	
NET Capacity (cubic ft.)	15.2
Capacity- Top holding area	(8) 3 Gallon tubs
Capacity- Bottom holding area	(6) 3 Gallon tubs
ELECTRICAL DATA	
Full Load Amperes	5.4
REFRIGERATION DATA	
Horsepower	1/3
Capacity (BTU/Hr)	1130
Heat Rejection (BTU/Hr)	1695
Charge (lbs/grams)	0.198/90
WEIGHT DATA	
Gross Weight	261 lbs
Height - Crated	53"
Width - Crated	44"
Depth - Crated	28"

Dipping Cabinet Freezer Model: BDC-HC-8

Model Views

Required Clearance: 4" Sides & Rear

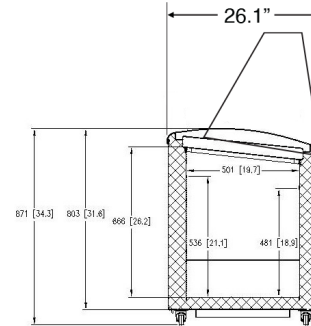

SIDE VIEW

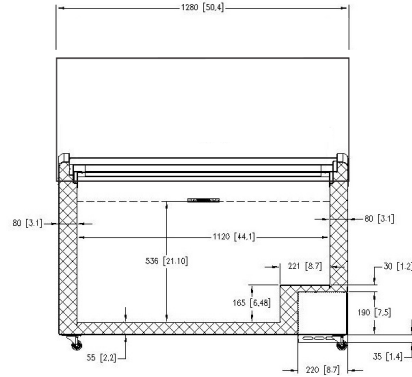

ELEVATION VIEW



ELECTRICAL CONNECTION



115/60/1
NEMA 5-15P

Units pre-wired at
factory and include 6.5'
long cord and plug set.