



America

www.BakeMax.com

Project: \_\_\_\_\_

Item: \_\_\_\_\_

Qty: \_\_\_\_\_ Date: \_\_\_\_\_

## BakeMax America BACG Series Manual Gas Griddle



Model BACG24

The BakeMax America BACG Series Manual Gas Griddle is designed to provide the ultimate performance and durability. As with all our heavy-duty countertop equipment, they are built to the highest commercial standards to ensure years of trouble-free service, featuring superior frame construction and stainless-steel exterior for easy maintenance. Combine all of this and our affordable prices and you have the best value for your budget.

### Features:



- Available in 15", 24", 36", 48" and 60".
- Stainless Steel Front & Sides
- 3/4" Thick polished carbon steel working griddle plate.
- Enameled burners, designed to achieve the best performance, providing a more uniform roast with low consumption.
- Each burner produces 30,000 BTU
- Enameled burners placed every 12", providing uniformity when operating.
- Stainless steel splash guards around the top of the griddle
- Easily removable stainless steel griddle grease trap
- 3/4" rear gas connects
- Adjustable 4" Chrome Stainless Steel Legs
- LP conversion kit included
- Two-year limited parts and labor warranty



\*\* Due to continuous product improvement, specifications are subject to change without notice.

**BakeMax ® / Titan Ventures International Inc.**

### Warehouses:

270 Baig Blvd, Suite A3, Moncton, NB, E1E1C8   
1605 Crescent Cr Carrollton, TX, Dallas, TX 75006 

**Toll Free:** 1-800-565-BAKE (2253)

**Phone:** 506-858-8990

**Fax:** 506- 859-6929

**Email:** Sales@BakeMax.com

### BakeMax America BACG Series Manual Gas Griddle

#### Technical Specifications & Drawings

Model	Width	Depth	Height	Burners	BTU NG	BTU LP	Orifice #	
							Gas	LP
BACG15	15" (380mm)	30.5" (775mm)	16.8" (428mm)	1	30,000	30,000	33	51
BACG24	24" (610mm)	30.5" (775mm)	16.8" (428mm)	2	60,000	60,000	33	51
BACG36	36" (915mm)	30.5" (775mm)	16.8" (428mm)	3	90,000	90,000	33	51
BACG48	48" (1220mm)	30.5" (775mm)	16.8" (428mm)	4	120,000	120,000	33	51
BACG60	60" (1525mm)	30.5" (775mm)	16.8" (428mm)	5	150,000	150,000	33	51

**\*Warning:** The minimum supply pressure on this appliance must be set at 4 water column inches for natural gas and 10 water column for propane gas. Each unit has a 3/4" gas connect at the rear of the appliance.

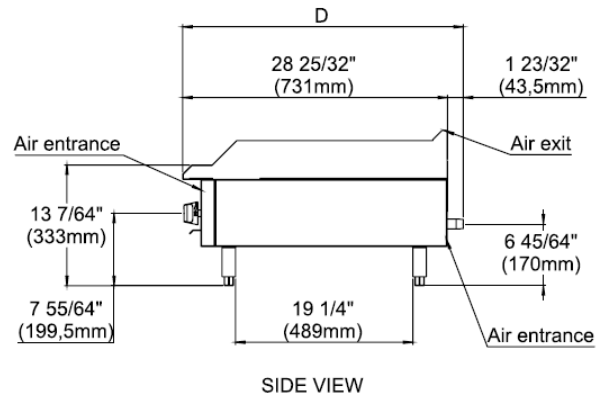
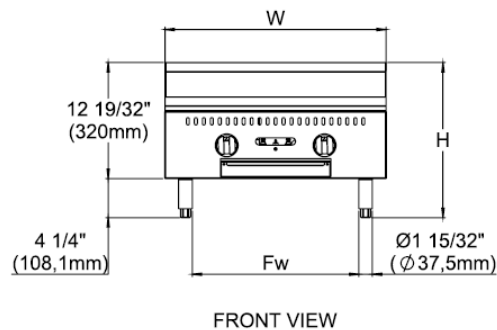
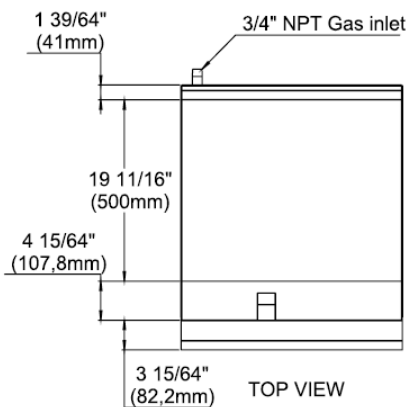

#### Shipping Information

Model	Net Weight lbs/kg	Crated Weight lbs/kg	Crate Dimensions (D x W x H)
BACG18	108lbs/49kg	132lbs/60kg	34"X16"X20"
BACG24	163lbs/74kg	194lbs/88kg	34"X28"X20"
BACG36	227lbs/103kg	273lbs/124kg	34"X41"X20"
BACG48	315lbs/143kg	353lbs/160kg	34"X53"X20"
BACG60	360lbs/163kg	430lbs/195kg	34"X64"X20"



BakeMax<sup>®</sup> / Titan Ventures International Inc.

**Warehouses:**

270 Baig Blvd, Suite A3, Moncton, NB, E1E1C8   
 1605 Crescent Cr Carrollton, TX, Dallas, TX 75006 

Toll Free: 1-800-565-BAKE (2253)

Phone: 506-858-8990

Fax: 506- 859-6929

Email: Sales@BakeMax.com