



BEVERAGE-AIR

Project: _____
 Item: _____
 Location: _____
 Approved: _____

AIA#

SIS#

SPE72HC SANDWICH PREP: DUAL SIDED MEGA TOP

FOOD PREPARATION TABLES

SPE72HC Sandwich Prep Table Dual Sided Mega Top Hydrocarbon Series

**MODEL:
SPE72HC-30M-DS**



**5 Year Parts/Labor Warranty Available
7 Year Compressor Warranty**

CABINET CONSTRUCTION

- Stainless steel front, sides, top, doors and grille (galvanized back & bottom)
- Interior liner is made of corrosion resistant aluminum
- Full electronic control
- Dual sided mega top
- Removable hoods made of matching stainless steel
- Self-closing doors with 120° stay-open feature, on cartridge style hinges
- Easy door removal for service and cleaning
- Field-reversible doors (hinge kit not included)
- Snap-in magnetic gaskets for positive door seal
- Painted aluminum door handles
- 6" Casters, with (2) brakes standard
- 10" & 12" wide cutting board constructed of white polyethylene plastic
- Cutting board removable for cleaning
- Six (6) epoxy-coated steel wire shelves
- Thirty (30) 1/6 4" deep pans constructed of polycarbonate plastic

OPTIONS & ACCESSORIES

- 3 Year parts/labor standard, additional 2 year warranty available
- Stainless steel back
- Stainless steel interior
- Door locks
- Overshelves (single or double)
- Crumb catcher kit
- Richlite cutting board
- Night cover
- Epoxy coated shelves
- Shelf clips
- Shelf dividers
- Bottle organizer
- Bun rack
- Pan supports
- Pan support crossbar
- 6" Legs or 3" casters
- Low profile casters
- Remote option* (see note on back page)

REFRIGERATION SYSTEM

- Uses environmentally friendly, energy efficient R290 refrigerant, and meets all regulatory requirements for CARB, SNAP, DOE & more
- Adaptive defrost
- Epoxy coated evaporator coil
- Maintains product temperatures between 36° - 38°F



 Please verify qualifying units by visiting:
www.energystar.gov/cfs

3779 Champion Blvd., Winston-Salem, NC 27105
 1-888-845-9800 Fax: 1-336-245-6453
 Beverage-Air.com Sales@bevair.com



BEVERAGE-AIR

MODEL	SPE72HC-30M-DS
EXTERNAL DIMENSIONAL DATA	
Width Overall	72"
Depth Overall	48 1/2"
Height Overall with Casters	46 3/4"
No. of Doors	3
Depth with Door Open 90°	62 3/8"
Door Openings	19 1/2" x 21 5/8"
Width, Cutting Boards	10" & 12"
INTERNAL DIMENSIONAL DATA	
NET Capacity (cubic ft.)	20.02
Internal Width Overall (in)	68"
Internal Depth Overall (in)	23 3/8"
Internal Height Usable (in)	17 3/4"
No. of Shelves	6
No. of Pans	30
ELECTRICAL DATA	
Full Load Amperes	5.4
REFRIGERATION DATA	
Horsepower	1/3
Capacity (BTU/Hr)	1549
Heat Rejection (BTU/Hr)	2323.5
Charge (lbs/grams)	0.2095/95
SHIPPING DATA	
Gross Weight - Crated	504 lbs
Height - Crated	38"
Width - Crated	74"
Depth - Crated	49"

*NOTE: Remote units are field wired and come with 6" legs. Refrigerant must be specified at time of order.

Food Preparation Table: Dual Sided Mega Top Model: SPE72HC-30M-DS

Model Views

Required Clearance: 3" bottom & 2" rear

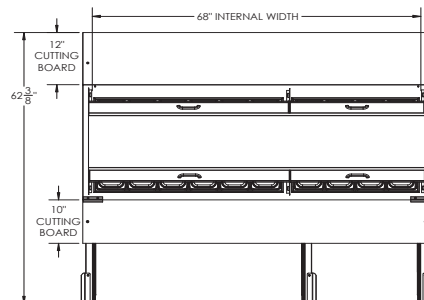

PLAN VIEW

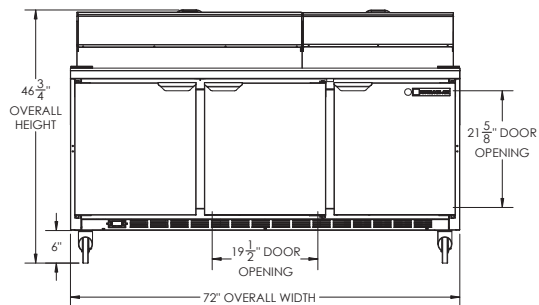

ELEVATION VIEW

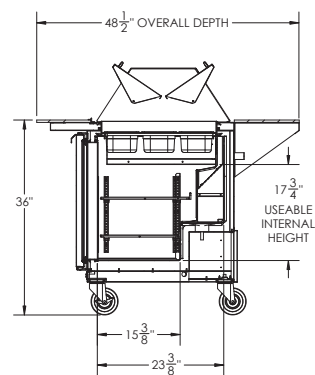

SIDE VIEW



ELECTRICAL CONNECTION



115/60/1
NEMA 5-15P

Unit pre-wired at factory and include 8' long cord and plug set.