



BEVERAGE-AIR

Project: _____	AIA#
Item: _____	
Location: _____	SIS#
Approved: _____	

SPE48HC SANDWICH PREP: SNEEZE GUARD

FOOD PREPARATION TABLES

SPE48HC Sandwich Prep Table With Sneeze Guard Hydrocarbon Series

MODEL:
SPE48HC-12-SNZ

5 Year Parts/Labor Warranty Available

7 Year Compressor Warranty



CABINET CONSTRUCTION

- Stainless steel front, sides, top, doors and grille (galvanized back & bottom)
- Interior liner is made of corrosion resistant aluminum
- Full electronic control
- Sneeze guard top
- Airflow assures that product in open containers is kept below 41°F and above freezing
- Self-closing door with 120° stay-open feature on cartridge style hinges
- Snap-in magnetic gaskets for positive door seal
- Easy door removal for service and cleaning
- Field-reversible doors (hinge kit not included)
- Painted aluminum door handles
- 6" Casters, 2 with brakes standard
- 10" Wide cutting board constructed of white polyethylene plastic
- Cutting board removable for cleaning
- Four (4) epoxy-coated steel wire shelves
- Twelve (12) 1/6 4" deep pans constructed of polycarbonate plastic

OPTIONS & ACCESSORIES

- 3 Year parts/labor standard, additional 2 year warranty available
- Stainless steel back
- Stainless steel interior
- Left hinged door (at time of order)
- Door locks
- Overshelves (single or double)
- Crumb catcher kit
- Richlite cutting board
- Night cover
- Epoxy coated shelves
- Shelf clips
- Shelf dividers
- Bottle organizer
- Bun rack
- Pan supports
- Pan support crossbar
- 6" Legs or 3" casters
- Low profile casters
- Remote option* (see note on back page)

REFRIGERATION SYSTEM

- Uses environmentally friendly, energy efficient R290 refrigerant, and meets all regulatory requirements for CARB, SNAP, DOE & more
- Adaptive defrost
- Epoxy coated evaporator coil
- Enhanced airflow maintains temperatures between 36° - 38°F



Please verify qualifying units by visiting:
www.energystar.gov/cfs

3779 Champion Blvd., Winston-Salem, NC 27105
1-888-845-9800 Fax: 1-336-245-6453
Beverage-Air.com Sales@bevair.com



BEVERAGE-AIR

Food Preparation Table: With Sneeze Guard Model: SPE48HC-12-SNZ

MODEL	SPE48HC-12-SNZ
EXTERNAL DIMENSIONAL DATA	
Width Overall	48"
Depth Overall	32"
Height Overall with Casters	53 1/8"
Number Doors	2
Depth with Door Open 90°	52 1/4"
Door Opening	19 5/8" x 21 5/8"
INTERNAL DIMENSIONAL DATA	
NET Capacity (cubic ft.)	13.01
Internal Width Overall (in)	44"
Internal Depth Overall (in)	15 3/8"
Internal Height Usable (in)	23"
No. of Shelves	4
No. of Pans	12
ELECTRICAL DATA	
Full Load Amperes	2.0
REFRIGERATION DATA	
Horsepower	1/6
Capacity (BTU/Hr)	1094
Heat Rejection (BTU/Hr)	1641
Charge (lbs/grams)	0.243/110
SHIPPING DATA	
Gross Weight - Crated	308 lbs
Height - Crated	47"
Width - Crated	51"
Depth - Crated	33"

*NOTE: Remote units are field wired and come with 6" legs.
Refrigerant must be specified at time of order.

Model Views

Required Clearance: 3" bottom & 2" rear

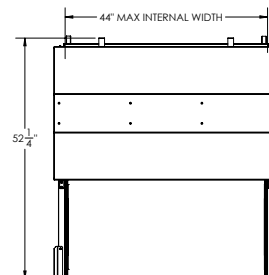

PLAN VIEW

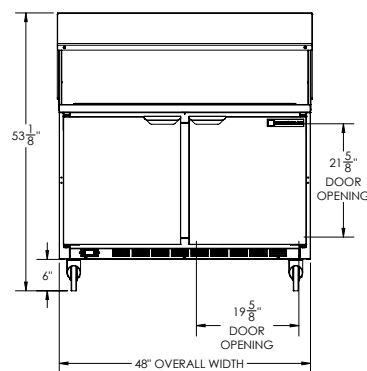

ELEVATION VIEW

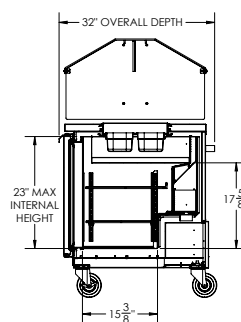

SIDE VIEW



ELECTRICAL CONNECTION

115/60/1
NEMA 5-15P

Unit pre-wired at factory
and include 8' long cord
and plug set.