



BEVERAGE-AIR

Project: _____	AIA#
Item: _____	
Location: _____	SIS#
Approved: _____	

MMRR72HC GLASS DOOR MERCHANDISER SERIES - DUAL-TEMP WINE

MARKETMAX® WINE DUAL-TEMP REFRIGERATOR/REFRIGERATOR

MODEL:
MMRR72HC-1-C-BW-WINE

MMRR72HC Black Hinged Triple Glass Door

Hydrocarbon Series

5 Year Parts/Labor Warranty Available

7 Year Compressor Warranty



CABINET CONSTRUCTION

- Exterior features durable black painted steel
- Heavy-duty interior construction includes white coated steel walls
- Modern one-piece grille
- Full electronic control
- Door locks
- Dual-temp refrigerator/refrigerator units provide two different operating temperature zones for different types of products
- Refrigerators have double pane lowE argon filled glass doors
- Self-closing doors with 120° stay-open feature
- Snap-in gaskets, easy to remove for cleaning or replacement
- LED lighting
- Brightly lit sign panel
- Fifteen (15) heavy-duty epoxy coated wire shelves
- Four (4) shelf clips included per shelf
- Self-contained bottom mount refrigeration system
- Leveling feet standard

OPTIONS & ACCESSORIES

- 3 Year parts/labor standard, additional 2 year warranty available
- Stainless steel or white exterior
- Stainless steel or black interior
- Wine rack upgrades: flat and curved (see page 3 for options)
- Additional shelves
- Shelf clips
- 3" or 6" Casters
- 6" Legs or seismic/flanged legs
- Custom wine signage (see page 3 for options)
- Left and right hand door swing (at time of order)
- Remote option* (see note on back on page)

REFRIGERATION SYSTEM

- Uses environmentally friendly, energy efficient R290 refrigerant, and meets all regulatory requirements for CARB, SNAP, DOE & more
- Non-electric defrost with hot gas condensate evaporation
- Epoxy coated evaporator coil
- Maintains product temperatures between 35°F to 62°F



 ENERGY STAR
Please verify qualifying units by visiting:
www.energystar.gov/cfs

3779 Champion Blvd., Winston-Salem, NC 27105
1-888-845-9800 Fax: 1-336-245-6453
Beverage-Air.com Sales@bevair.com



BEVERAGE-AIR

MODEL	MMRR72HC-1-C-BW-WINE
EXTERNAL DIMENSIONAL DATA	
Width Overall	75 1/8"
Depth Overall (with handle)	33 1/2"
Height Overall	78 1/8"
Number of Doors	3
Depth with Door Open 90°	55 1/8"
Door Openings (in)	21 7/8" x 52 5/8"
INTERNAL DIMENSIONAL DATA	
NET Capacity (left/right section) (cubic ft.)	(R) 44.85 (R) 19.62
Internal Width (left section) (in)	47"
Internal Width (right section) (in)	22"
Internal Depth Overall (in)	27"
Internal Height Usable (in)	53"
Number of Shelves	15
ELECTRICAL DATA	
Full Load Amperes (left section)	2.4
Full Load Amperes (right section)	2.4
REFRIGERATION DATA	
Horsepower	R 1/4 - R 1/4
Capacity (BTU/Hr) (left/right section)	(R) 3020 (R) 2317
Heat Rejection (BTU/Hr)	8005.5
Charge (lbs/grams/ounce) (left/right section)	(R) .1433 / 65 / 2.30 (R) .1433 / 65 / 2.30
SHIPPING DATA	
Gross Weight (crated lbs)	950 lbs
Height - Crated	85"
Width - Crated	77"
Depth - Crated	36"

*NOTE: Remote units are field wired and come with 6" legs.
Refrigerant must be specified at time of order.

Dual-Temp Wine Glass Door Merchandisers

Model: MMRR72HC-1-C-BW-WINE

Model Views

Required Clearance: Bottom & Rear 3"

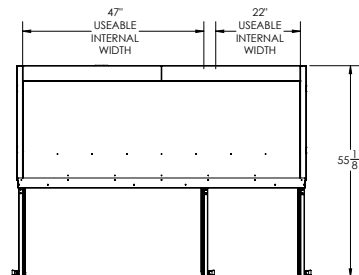

PLAN VIEW

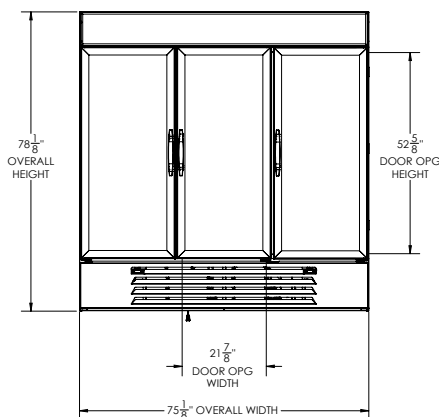

ELEVATION VIEW

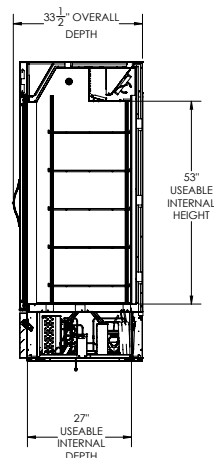

SIDE VIEW

ELECTRICAL CONNECTION



115/60/1
(2) NEMA 5-15P

Unit pre-wired at factory and include 8' long cord and plug set.



3779 Champion Blvd., Winston-Salem, NC 27105 1-888-845-9800 Fax: 1-336-245-6453 Beverage-Air.com Sales@bevoir.com

an Ali Group Company



The Spirit of Excellence



BEVERAGE-AIR®

WINE OPTION UPGRADES

SIGNAGE

Two wine header panels to choose from to call attention to the wine selection



SHELVING

We offer curved and flat wine racks, designed to secure the bottles while keeping them prominently on display. Available in white, black, and chrome finish.

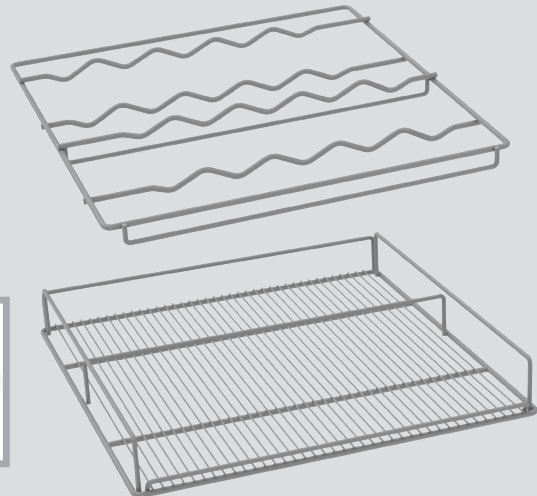

CONTROLLER

Easily programmed to keep unit and its contents at the necessary set point (between 35-62° F)



