



BEVERAGE-AIR

Project: _____	AIA#
Item: _____	
Location: _____	SIS#
Approved: _____	

HBRF72HC BOTTOM MOUNT DUAL TEMPERATURE REFRIGERATOR/FREEZER

DUAL TEMPERATURE REFRIGERATOR/FREEZER

MODEL:
HBRF72HC-1-C

HBRF72HC Solid Door Bottom Mount Reach-In

Hydrocarbon Series

5 Year Parts/Labor Warranty Available

7 Year Compressor Warranty

CABINET CONSTRUCTION

- Stainless steel front, side, and grille (galvanized back & bottom)
- Stainless steel interior
- Full electronic control with one-touch defrost
- Dual temp refrigerator/freezer units provide two different operating temperature zones for different types of products
- Left: refrigerator double section
- Right: freezer single section
- One-piece grille allows easy removal/installation for preventative maintenance
- Door locks standard
- Self closing doors, 120° stay open feature with spring-loaded style hinges
- Snap-in magnetic door gaskets for easy cleaning and replacement
- Nine (9) heavy-duty epoxy coated wire shelves
- LED lighting standard
- 6" Heavy-duty casters with (2) brakes
- Certified for open food product



OPTIONS & ACCESSORIES

- 3 Year parts/labor standard, additional 2 year warranty available
- Epoxy shelves
- Shelf clips
- 3" Casters or 6" legs
- Wine temperature control
- Door swing orientation (at time of order)
- Remote option* (see note on back page)

REFRIGERATION SYSTEM

- Uses environmentally friendly, energy efficient R290 refrigerant, and meets all regulatory requirements for CARB, SNAP, DOE & more
- Adaptive defrost
- Epoxy coated evaporator coil
- Refrigerator maintains product temperatures between 36°F to 38°F
- Freezer maintains product temperature to -10°F



Please verify qualifying units by visiting:
www.energystar.gov/cfs

3779 Champion Blvd., Winston-Salem, NC 27105
1-888-845-9800 Fax: 1-336-245-6453
Beverage-Air.com Sales@bevair.com



BEVERAGE-AIR

MODEL	HBRF72HC-1-C
EXTERNAL DIMENSIONAL DATA	
Width Overall	75"
Depth Overall (with handles)	33 3/4"
Height Overall (with casters)	84 1/8"
Number of Doors	3
Depth with Door Open 90°	55 1/4"
Door Openings (in)	21 7/8" x 52 3/4"
INTERNAL DIMENSIONAL DATA	
NET Capacity (cubic ft.)	(R) 44.85 (F) 19.62
Internal Width Overall (in)	(R) 47" (F) 22"
Internal Depth Overall (in)	28 1/2"
Internal Height Usable (in)	55"
Number of Shelves	9
ELECTRICAL DATA	
Full Load Amperes	(R) 3.9 (F) 6.34
REFRIGERATION DATA	
Horsepower	(R) 1/3 (F) 3/4
Capacity (BTU/Hr)	(R) 2291 (F) 2097
Heat Rejection (BTU/Hr)	6582
Charge (lbs/grams/ounce)	(R) 0.2425 / 110 / 3.88 (F) .2094 / 95 / 3.35
SHIPPING DATA	
Gross Weight - Crated	762 lbs
Height - Crated	88"
Width - Crated	77"
Depth - Crated	45"

*NOTE: Remote units are field wired and come with 6" legs.
Refrigerant must be specified at time of order.

Dual Temp Bottom Mount Reach-In Solid Door Refrigerator/Freezer Model: HBRF72HC-1-C

Model Views

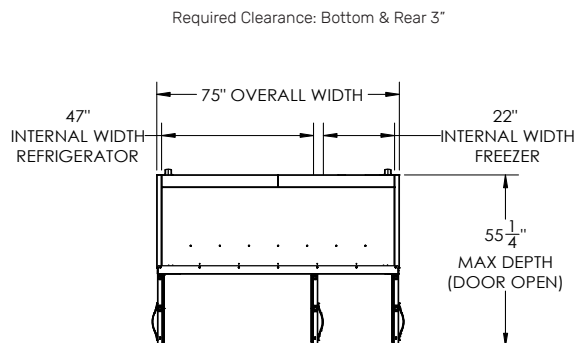

PLAN VIEW

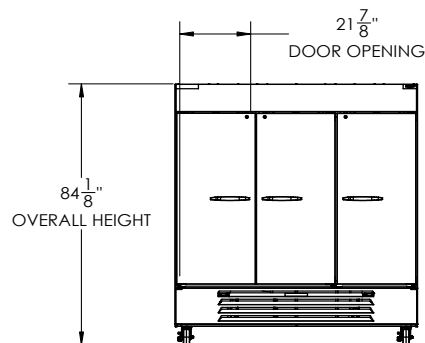

ELEVATION VIEW

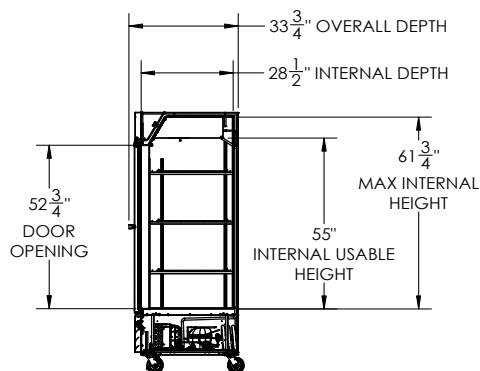

SIDE VIEW

ELECTRICAL CONNECTION



115/60/1
(2) NEMA 5-15P

Unit pre-wired at factory
and include 8' long cord
and plug set.



3779 Champion Blvd., Winston-Salem, NC 27105 1-888-845-9800 Fax: 1-336-245-6453 Beverage-Air.com Sales@bevair.com

an Ali Group Company



The Spirit of Excellence